

Jonah Center for Earth and Art  
**Walking Trail and Kayak Launch**  
Middletown, Connecticut



**Eastern Connecticut  
Environmental Review Team  
Report**

Eastern Connecticut Resource Conservation & Development Area, Inc.

# Jonah Center for Earth and Art Walking Trail and Kayak Launch Middletown, Connecticut



**Environmental Review Team Report**

**Prepared by the  
Eastern Connecticut Environmental  
Review Team  
Of the  
Eastern Connecticut  
Resource Conservation &  
Development Area, Inc.**

**For the**

**City of Middletown and the Jonah  
Center for Earth and Art  
Middletown, Connecticut**

**May 2006**

**Report #595**

## ACKNOWLEDGMENTS

This report is an outgrowth of a request from the City of Middletown and the Jonah Center for Earth and Art to the Connecticut River and Coastal Conservation District (CRCCD) and the Eastern Connecticut Resource Conservation and Development Area (RC&D) Council for their consideration and approval. The request was approved and the measure reviewed by the Eastern Connecticut Environmental Review Team (ERT).

The Eastern Connecticut Environmental Review Team Coordinator, Elaine Sych, would like to thank and gratefully acknowledge the following Team members whose professionalism and expertise were invaluable to the completion of this report.

The field review took place on, Thursday, December 22, 2005.

Wendy Goodfriend	Resource Conservationist CT River and Coastal Conservation District (860) 346-3284
Robert Haramut	Transportation Planner Midstate Regional Planning Agency (860) 347-7214
Joseph Hickey	Recreation Planner CT Greenways Council (860) 529-4363
Alan Levere	Wetland Reviewer DEP – Office of the Commissioner (860) 424-3643
Dawn McKay	Biologist/Environmental Analyst 3 DEP - Environmental and Geographic Information Center (860) 424-3592
Brian Murphy	Senior Fisheries Biologist DEP - Inland Fisheries Division (860) 295-9523
Nisha Patel	Sanitary Engineer III DEP – PERD (860) 424-3840

Sally Snyder  
CT River Basin Coordinator  
Watershed Management Program  
(860) 424-3869

Julie Victoria  
Wildlife Biologist  
DEP – Franklin Wildlife Management Area  
(860) 642-7239

I would also like to thank John Hall and Diana Lane of the Jonah Center, Bill Warner and Rick Kearney of the City of Middletown, and David McKeegan of the DEP Waste Engineering and Enforcement Division for their cooperation and assistance during this environmental review. Jane Brawerman and Paul Woodworth from the CRCCD also accompanied the field walk.

Prior to the review day, each Team member received a summary of the proposed project with location and soils maps. During the field review Team members were able to discuss issues and other reports and maps available. Some Team members made separate or follow-up visits to the site. Following the review, reports from each Team member were submitted to the ERT coordinator for compilation and editing into this final report.

This report represents the Team's findings. It is not meant to compete with private consultants by providing site plans or detailed solutions to development problems. The Team does not recommend what final action should be taken on a proposed project - all final decisions rest with the city and Jonah Center. This report identifies the existing resource base and evaluates its significance to the proposed use, and also suggests considerations that should be of concern to the city. The results of this Team action are oriented toward the development of better environmental quality and the long term economics of land use.

The Eastern Connecticut RC&D Executive Council hopes you will find this report of value and assistance in reviewing the proposed trail and kayak launch.

If you require additional information please contact:

Elaine Sych, ERT Coordinator  
CT ERT Program  
P. O. Box 70  
Haddam, CT 06438  
Tel: (860) 345-3977 e-mail: [ctert@comcast.net](mailto:ctert@comcast.net)

# TABLE OF CONTENTS

	PAGE
Acknowledgments	3
Table of Contents	5
Introduction	6
A Watershed Perspective	11
Conservation District Review	17
Wetland Review	25
Stormwater Management	34
Fisheries Resources	37
The Natural Diversity Data Base	39
Recreation Planning Review	41
Traffic Considerations	43
Appendix	44
Trail Creation and Maintenance Documents	
DEP – Wildlife in CT – Endangered & Threatened Species Series	

# INTRODUCTION

## Introduction

The City of Middletown and the non-profit Jonah Center for Earth and Art have requested Environmental Review Team (ERT) assistance in reviewing a proposed walking trail and kayak launch at the North End Peninsula, at the confluence of the Coginchaug and Mattabessett Rivers.

The 45 acre site contains the 27 acre capped and closed Middletown landfill. A portion of the site currently serves as the city's recycling center. The proposed walking trail would wind its way around and over the landfill which provides spectacular views of the Coginchaug and Mattabessett Rivers and the Cromwell Meadows wetlands. The kayak launch is proposed for the east side of the site on the Mattabessett River, but Team members also looked at a possible area along the Coginchaug River on the western side of the site. Team members differed in their opinions and recommendations regarding the location of the kayak launch. Further study will be needed to determine which site is feasible.

The walking trail and kayak launch are the initial stages of a much larger proposed project which eventually envisions an environmental education center on the peninsula, under the auspices of the Jonah Center.

## Objectives of the ERT Study

The purpose of this review is to provide baseline information for the site and to provide information on how to best turn this location into a significant environmental, educational and recreational asset for the City of Middletown. Information and areas of concern include: soils, erosion and sediment control, trail development, stormwater management, wetlands and river habitats, aquatic habitats, recreation considerations for walking and kayaking, and any other opportunities and limitations.

## The ERT Process

Through the efforts of the City of Middletown and the Jonah Center this environmental review and report was prepared for the City of Middletown and the Jonah Center.

This report provides an information base and a series of recommendations and guidelines which cover the topics requested by the town. Team members were able to review maps, plans and supporting documentation provided by the applicant.

The review process consisted of four phases:

1. Inventory of the site's natural resources;
2. Assessment of these resources;
3. Identification of resource areas and review of plans; and
4. Presentation of education, management and land use guidelines.

The data collection phase involved both literature and field research. The field review was conducted Thursday, December 22, 2006. The emphasis of the field review was on the exchange of ideas, concerns and recommendations. Being on site allowed Team members to verify information and to identify other resources.

Once Team members had assimilated an adequate data base, they were able to analyze and interpret their findings. Individual Team members then prepared and submitted their reports to the ERT coordinator for compilation into this final ERT report.





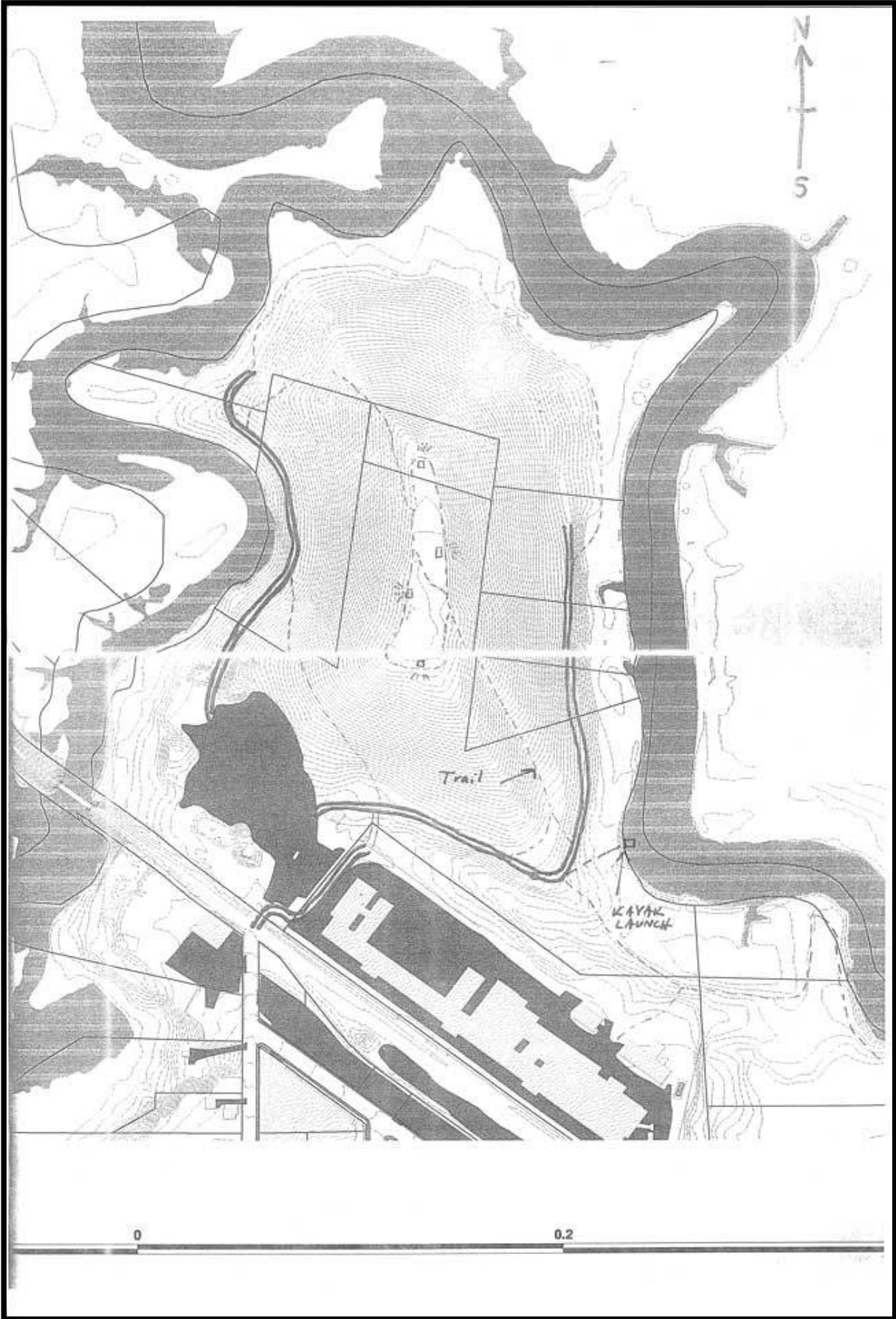

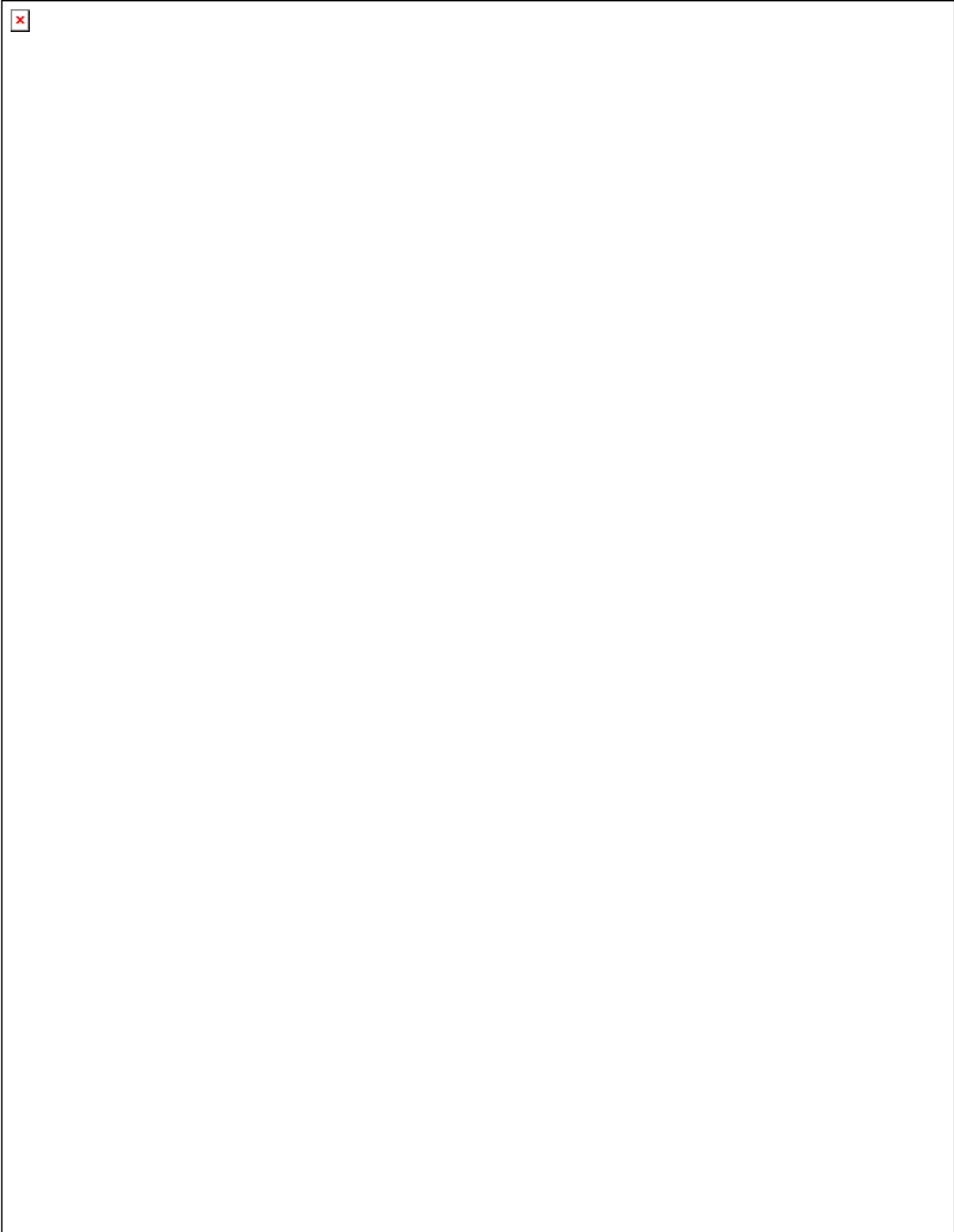

# A WATERSHED PERSPECTIVE

## Introduction

These comments are given from the perspective of improving and maintaining water quality and supporting designated uses of the State's waters in accordance with Connecticut's Water Quality Standards<sup>1</sup>. This information also reflects upon the Connecticut Department of Environmental Protection's (CTDEP) growing commitment to address water resource concerns from a watershed perspective, taking into account the cumulative impact that various land use policies and activities within a given watershed may have upon water resources.

The following remarks may overlap with those of other ERT members who are dealing with more specialized aspects of the review (i.e. fish and wildlife habitat, wetlands, stormwater erosion and sedimentation control, etc.). In such cases, these comments are meant to support or supplement their specialized reviews.

## Project Description

The proposed walking trail and kayak launch is located at the North End Peninsula at the confluence of the Coginchaug and Mattabesset rivers. The 45-acre site contains the 27-acre closed and capped municipal landfill, and the city's recycling center. Before considering siting a proposed environmental education center at the site, the area is first being reviewed for the proposed trail and launch.

The proposed trail will be handicapped accessible and will follow a route around the perimeter of the landfill above the flood elevation. The northerly and eastern sides of the landfill are surrounded by the 100-year floodway; the west (Coginchaug River's eastern shoreline) and the southern portion of the site are within 100-year floodplain; and the area entrance and recycling center are within the 500-year floodplain. Another trail is proposed to cross atop the landfill.

## Water Quality Classification

The Mattabesset River located north and east of the site is classified as having Class C/B water quality. According to Connecticut's Water Quality Standards, a classification of C/B denotes that, due to point or non-point sources of pollution, certain criteria or one or more designated uses assigned to Class B waters may not currently be met. Class B designated uses are: habitat for fish and other aquatic life and wildlife; recreation; navigation; and industrial and agricultural water supply. The water quality goal is achievement of Class B Criteria and attainment of Class B designated uses. The Coginchaug River to the west is classified as having Class B water quality. As such, it has the same designated uses and goal as stated above for the Mattabesset River.

---

<sup>1</sup> State of Connecticut, Department of Environmental Protection. Effective 1996 & 2002. Water Quality Standards. Bureau of Water Management, Planning and Standards Division. Hartford, CT.

To determine whether the State's surface water resources are meeting their designated uses, CTDEP monitors or collects samples from selected water bodies throughout the state. Generally, water quality is assessed based on the following three uses: fish consumption, aquatic life support, and primary contact (i.e. direct exposure) for recreation. The degree to which the water body is suitable for that use is assigned one of the following use support descriptors: fully supporting, threatened (fully supporting but threatened by impairment), partially supporting, not supporting, not attainable or not assessed. The degree to which these different uses are supported by the water body determines the "overall use support".<sup>2</sup>

This section of the Mattabesset River is listed as being fully supportive of fish consumption, but was not assessed for aquatic life support, primary contact, or overall use support, although a potential source of impairment is listed as turbidity and suspended solids from urban runoff/storm sewers. The Coginchaug River at this location has been assessed as being fully supportive of fish consumption, threatened for primary contact due to pathogens and indicator bacteria from unknown sources, and not assessed for aquatic life support or overall use support.

The groundwater designation for the site is Class GB which has the following designated uses: industrial process water and cooling waters; baseflow for hydraulically connected surface water bodies; and presumed not suitable for human consumption without treatment due to waste discharges, spills or leaks of chemicals or land use impacts. Ground waters of this class are assumed by the Department to be degraded due to a variety of pollution sources. No specific groundwater quality criteria apply. This is indicative of a historically highly urbanized area or an area of intense industrial activity and where public water supply service is available, and where groundwater may be used for assimilation of discharges by permit, e.g. landfill leachate.

## Canoe/Kayak Launch

Park amenities include a proposed canoe/kayak launch at the southeast corner of the site adjacent to wetlands associated with the Mattabesset River near a stream channel or drainage ditch flowing from the southern end of the site. Reportedly, this channel has had discolored discharges but it is not clear whether these were due to contamination or natural conditions. The proposed canoe/kayak launch site has room for approximately 6 cars to park. In order to reach the Mattabesset River, there would likely need to be a boardwalk or some other walkway to pass through the wetlands, however, if the proposed access or launch would impact tidal wetlands, this may not be permissible by the CTDEP Office of Long Island Sound Programs. Tidal wetlands are those areas which border on or lie beneath tidal waters or are subject to tidal action, including those areas now or formerly connected to tidal waters, and whose surface is at or below an elevation of one foot above local extreme high water; which may grow or be capable of growing some, but not necessarily all, of the plant species listed under Section 22a-29 of the Connecticut General Statutes. Conversely, if the proposed canoe/kayak launch were located on the west side of the landfill on the eastern bank of the

---

<sup>2</sup> State of Connecticut, Department of Environmental Protection. April, 2004. 2004 Water Quality Report to Congress. Bureau of Water Management, Planning and Standards Division. Hartford, CT.

Coginchaug River, tidal wetlands may be avoided. Please note that the water resources near and around the landfill may not be suitable for swimming, and that “no swimming” signs should be posted.

## Safety

There is no doubt that the selected site offers an unparalleled scenic vista atop the landfill of the marsh and riverine habitats along the Coginchaug and Mattabesset rivers as they converge with the Connecticut River. However, care should be taken not to unduly expose visitors to potentially harmful or sickening effects that may be associated with the closed landfill, such as methane emission or leachate breakout. It was noted that certain sections of the capped landfill had no vegetative cover, which was attributed to gas exposure (as opposed to erosion although there were occasional signs of rilling, gullyng or other forms of slope failure). There is currently no methane collection system in place.

Entering the site via Johnson Street Extension requires crossing the Providence & Worcester Railroad freight line. Although this is a public at-grade crossing, there is no signal or gate. Additional signage may be necessary to warn visitors, or routine road maintenance to optimize usage. For additional information, contact CTDOT’s Rail Regulatory Unit, Gil Smart at telephone (203) 789-7189 extension 155, e-mail: [gilbert.smart@po.state.ct.us](mailto:gilbert.smart@po.state.ct.us), and Connecticut’s Operation Lifesaver, Pam Guinan at telephone (860) 594-2824, e-mail: [pamela.guinan@po.state.ct.us](mailto:pamela.guinan@po.state.ct.us) for assistance.

Additionally, entry through the city’s recycling center and access to the west side of the landfill appears to be impeded by a number of stockpile areas. It would be helpful and perhaps even prudent to establish a clear path for access that would both lead and guard the trail user from potential hazards, including making it more visible for security purposes. This area also leads to a potential alternative canoe/kayak launch site.

## Mattabesset Regional Watershed

Regionally, the site straddles the drainage divide between the Mattabesset River watershed, subregional basin number 4600, and the Coginchaug River water, subregional basin number 4607. Both of these lie within the Mattabesset Regional Basin (#46). The CTDEP has completed a Total Maximum Daily Load (TMDL) analysis<sup>3</sup> for the Regional Basin for indicator bacteria. Included in the TMDL analysis are the Mattabesset and Coginchaug subregional basins. These waterbodies are included on the 2004 List of Connecticut Waterbodies Not Meeting Water Quality Standards<sup>4</sup>, with the exception of the river segments located within

<sup>3</sup> State of Connecticut, Department of Environmental Protection. May, 2005. A Total Maximum Daily Load Analysis for the Mattabesset River Regional Basin. Bureau of Water Management, Planning and Standards Division. Hartford, CT.

<sup>4</sup> State of Connecticut, Department of Environmental Protection. April, 2004. 2004 List of Connecticut Waterbodies Not Meeting Water Quality Standards. Bureau of Water Management, Planning and Standards Division. Hartford, CT.

the project area, due to exceedences of the indicator bacteria criteria contained in Connecticut's Water Quality Standards (WQS). While the proposed project poses no significant threat to water quality (provided patrons pick-up after their dogs), the overall protection of the watershed is essential to maintaining the scenic, wildlife and aquatic values that draw one to this site.

## **Total Maximum Daily Load**

A TMDL is a tool water quality managers use to address water quality problems. TMDLs provide the framework for restoring impaired waters by establishing the maximum amount of a pollutant that a waterbody can take without exceeding the water quality criteria for that parameter, without adverse impact to fish, wildlife, recreation, or other public uses. The end result is a Water Quality Management Plan with quantitative goals to reduce pollutant loadings to the impaired waterbody. Under section 303(d) of the Federal Clean Water Act (CWA), states are required to develop TMDLs for listed waterbodies for which technology-based controls are insufficient to achieve water quality standards. The Department then prioritizes waterbodies for TMDL development based on knowledge of the waterbody and pollutant, current resource availability, and programs in place to aid in TMDL implementation.

## **Municipal Separate Storm Sewer Systems General Permit**

The Mattabesset River Regional Basin is located within municipalities with urban areas, as defined by the U.S. Census Bureau. Such municipalities are required to comply with the General Permit for the Discharge of Stormwater from Small Municipal Separate Storm Sewer Systems (MS4 permit). The general permit is applicable to municipalities that contain designated urban areas (or MS4 communities) and discharge stormwater via a separate stormwater sewer system to surface waters, i.e. streams and rivers. The permit requires municipalities to develop a program aimed at reducing the discharge of pollutants, as well as to protect water quality. The permit includes a provision requiring towns to focus their stormwater plans on waterbodies for which TMDLs have been developed. Such a program must include the following six control measures: public education and outreach; public participation; illicit discharge detection and elimination; construction stormwater management (greater than 1 acre); post-construction stormwater management; and pollution prevention and good housekeeping. Specific requirements have been developed within each of these control measures. Additional information regarding the general permit can be obtained on the CTDEP website at <http://www.dep.state.ct.us/pao/download.htm#MS4GP>.

Bacteria impaired waterbodies located in MS4 communities were prioritized for TMDL analysis as part of CTDEP efforts to support the MS4 Permit. The Mattabesset River Regional Basin was prompted for immediate TMDL analysis because previous sampling indicated bacteria impairment in the subject waterbodies.

## **Watershed-Based Plan**

Complementing the TMDL program, under section 319(h) of the CWA through EPA, the CTDEP Nonpoint Source Management Grant Program has funded the USDA Natural

Resources Conservation Service (NRCS) to develop a watershed-based plan (WBP) for the Coginchaug River which will assist the Department in developing an effective approach for addressing the 303(d) listed impairments. The WBP will satisfy section 319 guidance and provide broader benefits to federal, state and local watershed management efforts, and provide the public with comprehensive water quality improvement plans by employing a watershed wide assessment and management plan. The WBP will strengthen the likelihood that practices addressing systemic issues (i.e. root causes of the water quality impairments) will be considered, evaluated, and implemented, not only to meet individual pollutant standards and criteria, but to satisfy related physical and biological management needs to the extent possible. The WBP will also provide a basis for directed use of section 319 Incremental Funds for projects that meet EPA interests and objectives. Equally important, this project will exemplify how cooperative partnerships between local, state, and federal government and citizens can enhance local capacity to implement the recommendations in the WBP.

The embodiment of this cooperative, collaborative approach is the CT River Coastal Conservation District (formerly Middlesex County Soil & Water Conservation District), which lead the Mattabeset River Stakeholder Group who spearheaded the development of the Management Plan for the Mattabeset River Watershed (September 2000). Additionally, the District's past efforts to monitor and identify impairments and on-going outreach will facilitate the development of the WBP and its implementation.

## **Recreation**

There is strong scientific evidence that providing access to places for physical activity increases the level of physical activity in a community, which is good for one's health. A trail may be constructed simply for pedestrian access or multiple uses, such as equestrians, bicyclists, roller bladers, baby strollers, joggers/runners, etc., but the trail design and route should be conducive to the natural terrain so as to minimize erosion and maintenance. Trail designs vary from at-grade stone dust paths to pavement of various widths and raised boardwalk crossings over wetlands and watercourses or as viewing platforms. With regard to promoting public access, it may be appropriate to construct a trail system that provides for scenic vistas, waterfront access, and wildlife viewing, besides merely pedestrian/bicyclist/equestrian use, provided that the terrain and habitat are suitable. Complementing nature trails with educational kiosks for animal tracks and sign, bird watching, and natural geologic features offer additional attractions that may increase usage by individuals and educational groups. If project resources are limited, construct a main trail loop that will allow future spurs to be constructed later, such as southward along the Coginchaug River and southeast of the site to Roosevelt Park. Additionally, the concern for public safety and illegal dumping may be reduced by limiting access to isolated areas until such time as popular use of the trail system is sufficient to provide enough traffic and visibility to discourage law-breakers. Future trail expansion is encouraged, but this may require lengthy and costly negotiations with adjacent property owners.

## **Greenway**

The next level of corridor protection is the establishment of a greenway. In 1995, State legislation was adopted which allows municipalities to adopt plans for greenways protection

and development into their “plans of conservation and development” (CGS Sec. 8-23). As defined by the State statute, “greenway” means:

a corridor of open space that (1) may protect natural resources, preserve scenic landscape and historical resources or offer opportunities for recreation or nonmotorized transportation, (2) may connect existing protected areas and provide access to the outdoors, (3) may be located along a defining natural feature, such as a waterway, along a man-made corridor, including an unused right-of-way, traditional trail routes or historic barge canals or (4) may be greenspace along a highway or around a village (CGS Sec. 23-100).

This same legislation also established the Connecticut Greenways Council that among other things, serves “to advise and assist in the coordination of state agencies, municipalities, regional planning organizations and private citizens in voluntarily planning and implementing a system of greenways” (CGS Sec. 23-102).

If there is local support to pursue designation of a greenway, there needs to be careful consideration as to the types of uses that would be allowed in this area. CTDEP suggests that opportunities to protect and conserve natural resources values such as water quality, fisheries, wildlife habitat and unique plant communities be considered first.

Adoption of a greenway in this region may provide additional opportunities for public access to “satellite” treks; however, these uses may need to be limited to minimize potential impacts on the natural resources themselves. For further guidance on establishing a greenway, contact the Connecticut Greenways Council, CTDEP Greenways Assistance Center, Leslie Lewis at telephone (860) 424-3578, e-mail: [leslie.lewis@po.state.ct.us](mailto:leslie.lewis@po.state.ct.us).

## Summary

The proposed site lends itself to the use of recreational trails, access to scenic vistas, and limited access to the Coginchaug, Mattabesset and Connecticut rivers. Safety considerations such as location and construction of the trails, and access over the existing railroad crossing require review but do not appear to be problematic. Conversely, locating the proposed canoe/kayak launch on the east side of the landfill where there are tidal wetlands may be difficult to obtain CTDEP authorization from the Office of Long Island Sound Programs. An alternative location exists on the west side of the landfill along the Coginchaug River. The existing stockpiles near the city’s recycling center should be relocated to allow clear and direct access to this side of the landfill.

Beyond utilizing this site for public recreation and educational opportunities, it is important to understand that the water resources here reflect land use and development patterns within the watershed. Protecting and restoring surface waters requires a watershed approach that involves the cooperation of state, federal and local authorities and the public. On going programs such as the MS4 General Permit, TMDL analysis, and Watershed Based Plan will assist in these efforts, but implementation requires participation by the watershed towns and general public.



## CONSERVATION DISTRICT REVIEW

The following are general comments and recommendations regarding the proposed walking trail, kayak/canoe launch and possible future environmental education center at the North End Peninsula in Middletown, CT. Comments from the Connecticut River Coastal Conservation District are advisory in nature, and are intended to assist municipal officials, agencies, and organizations in their charge.

### Current Site Conditions

*The North End Peninsula is 45 acres situated just south of where the Mattabeset River joins with one of its major tributaries, the Coginchaug River. The City's closed landfill, which encompasses more than half of the peninsula, provides panoramic views of the Coginchaug, Mattabeset, and Connecticut rivers. The City recycling transfer station occupies much of the south western portion of the site. Access from North Main Street into the area is currently through the transfer station.*

*The closed landfill is surrounded by a thin strip of 100-year flood zone (approximately 25-75 wide) and a wider floodway associated with the Mattabeset and Coginchaug rivers. The floodway can be defined as "the channel of a stream, plus any adjacent floodplain areas, that must be kept free of intrusions so that the 100-year flood can be carried without substantial increase in flood heights." Standards for allowable flood elevation increases in the floodway are restrictive; with only small increases generally allowed.*

**Figure 1.** FEMA floodzone mapping showing the 100-year flood zone (in green) and the floodway in yellow (1:24,000).

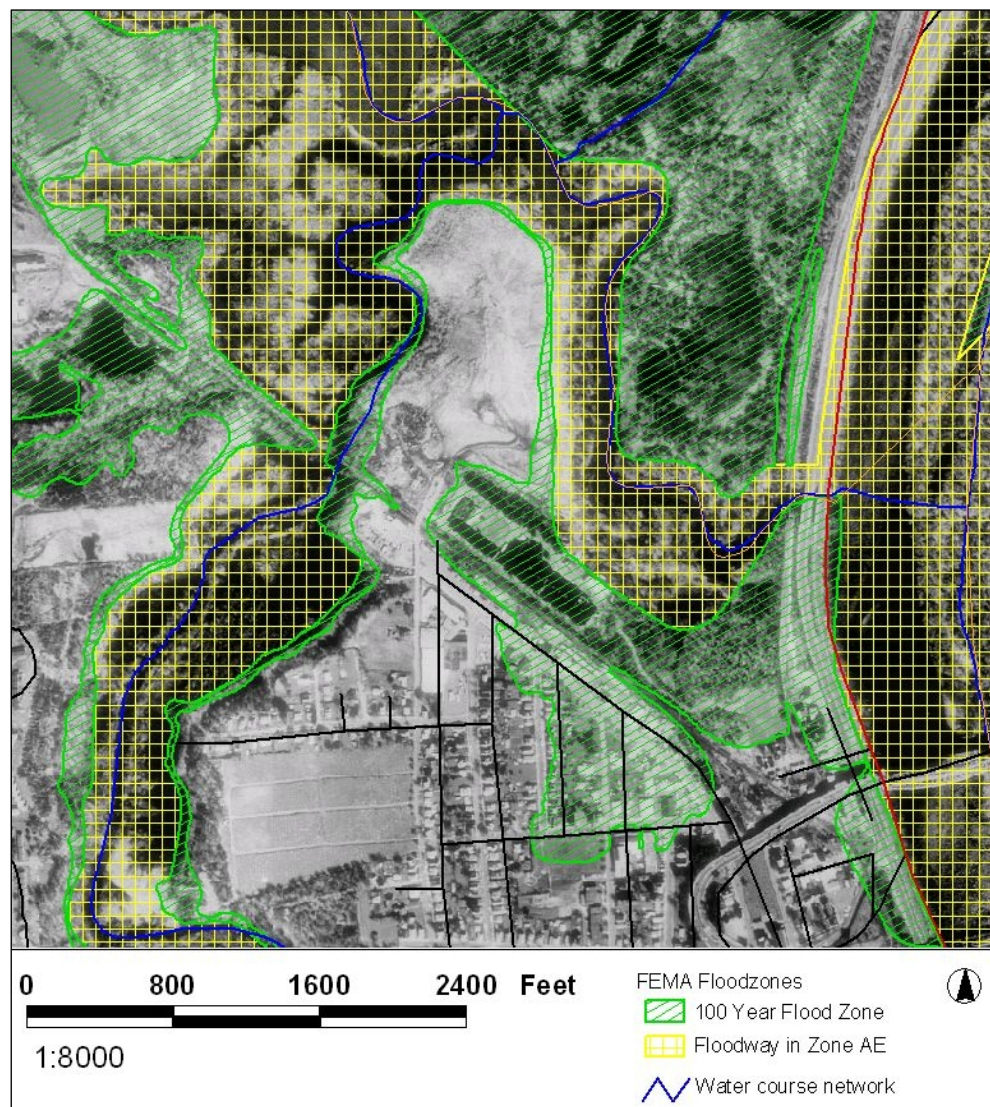

## Soils

Five wetlands soils and three upland soils types are shown on the USDA/NRCS soils GIS coverage. The landfill and transfer station portion of the North End Peninsula is comprised of disturbed, human modified soils (Urban Land and Dump) and upland Wethersfield loam. Floodplain and alluvial soils are associated with the Mattabesset and Coginchaug rivers. A small area of inland wetlands, not shown on the soils mapping, was observed north of the Remington-Rand Building.

*Table 1. Summary of upland and wetland soils mapped in the vicinity of the North End Peninsula*

<i>Symbol</i>	<i>Name</i>	<i>Description</i>
18	Catden and Freetown	Muck
102	Pootatuck fine sandy loam	Floodplain
103	Rippowam fine sandy loam	Floodplain
108	Saco silt loam	Floodplain
87D	Wethersfield loam	Upland
302	Dumps	Upland
307	Urban Land	Upland

**Figure 2.** Soil map units shown for the North End Peninsula (1:12,000-scale datalayer USDA/NRCS).

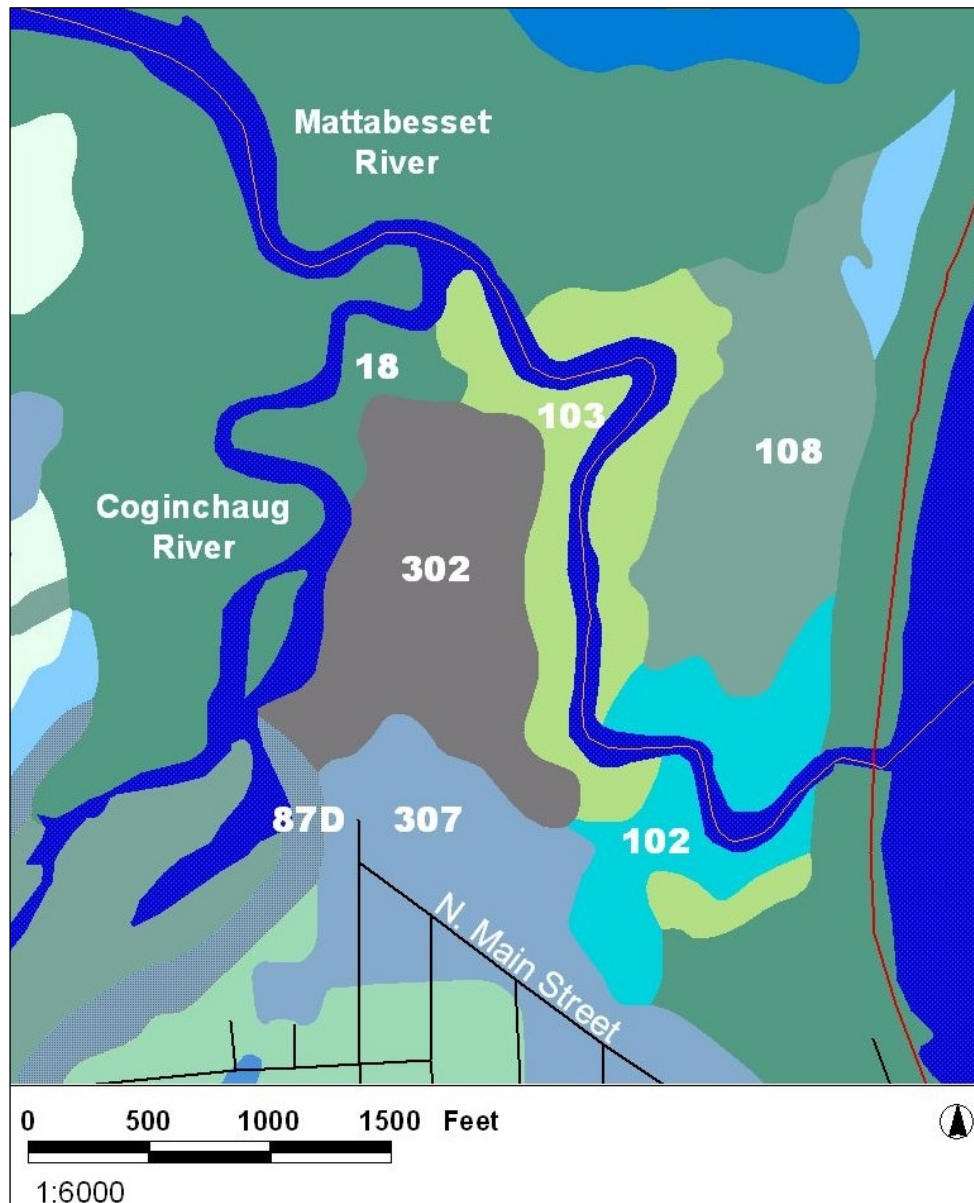



Catden and Freetown muck soils are broadly associated with the Mattabesset and Coginchaug river corridors to the north and west. A band of alluvial and floodplain soils are associated with the Mattabesset south of its confluence with the Coginchaug River to the Connecticut River. Floodplain soils are also shown associated with the Coginchaug River south of North Main Street. Soil map units from the USDA/NRCS GIS coverage are at a 1:12,000 scale, with the smallest area delineated approx. 3 acres. Caution should be taken when using the soil survey maps for site-level planning since at this scale soils in a single mapped unit can differ in slope, depth, drainage, and stoniness.

Select features and limitations of the seven soil map units are summarized in Table 2 and 3. The main soil features limiting recreational use of the area is the depth to the saturated zone, propensity for flooding and the organic content of the muck soils.

**Figure 3.** Extent of muck and floodplain soils shown on the statewide GIS soils mapping (1:12,000-scale datalayer USDA/NRCS).

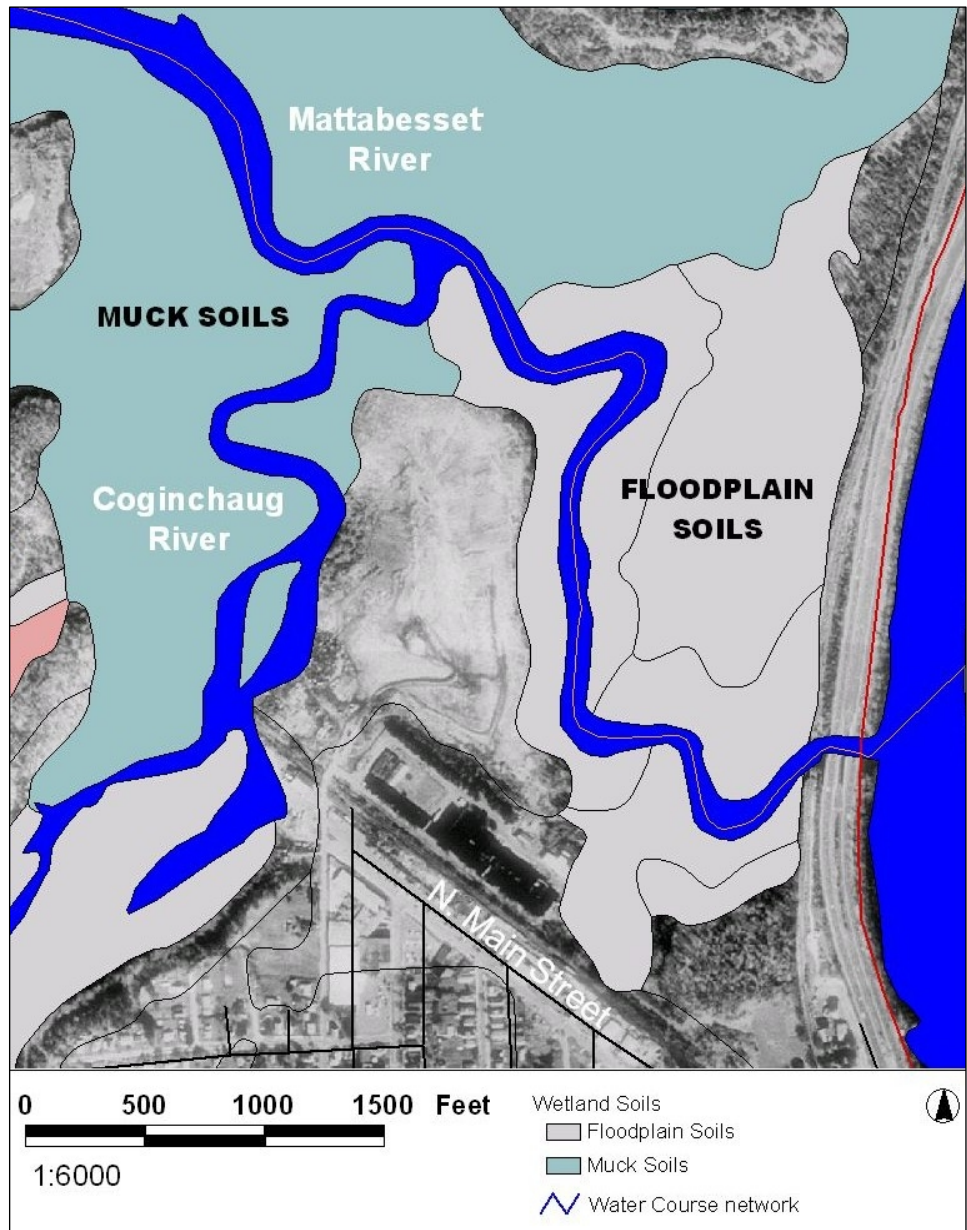

Below are descriptions of the mapped soil types based on the **Official Soil Series Descriptions** available from the NRCS Soil Survey Division online at: <http://soils.usda.gov/survey/>.

**Catden** This component occurs on lake plain, outwash plain, flood plain, moraine, till plain, valley, upland, depression, till plain landforms. The parent material consists of organic material. The slope ranges from 0 to 2 percent and the runoff class is negligible. The depth to a restrictive feature is greater than 60 inches. The drainage class is very poorly drained. The available water capacity is about 24.4 inches (very high). The flooding frequency for this component is rare. The ponding hazard is frequent. The minimum depth to a seasonal water table, when present, is about 4 inches.

**Freetown** This component occurs on depression, lake plain, moraine, outwash plain, till plain, upland, valley landforms. The parent material consists of woody organic material. The slope ranges from 0 to 2 percent and the runoff class is negligible. The depth to a restrictive feature is greater than 60 inches. The drainage class is very poorly drained. The available water capacity is about 33.1 inches (very high). The flooding frequency for this component is rare. The ponding hazard is frequent. The minimum depth to a seasonal water table, when present, is about 4 inches.

**Wethersfield** This component occurs on till plain, drumlin, upland, valley, hill landforms. The parent material consists of basal till derived from basalt, sandstone, and shale. The slope ranges from 15 to 25 percent and the runoff class is medium. The depth to a restrictive feature is 20 to 40 inches to densic material. The drainage class is well drained. The slowest permeability within 60 inches is about 0.00 in/hr (very slow), with about 4.3 inches (moderate) available water capacity. The ponding hazard is none. The minimum depth to a seasonal water table, when present, is about 24 inches.

**Pootatuck** This component occurs on river valley, flood plain landforms. The parent material consists of alluvium. The slope ranges from 0 to 3 percent and the runoff class is very low. The depth to a restrictive feature is greater than 60 inches. The drainage class is moderately well drained. The slowest permeability within 60 inches is about 0.57 in/hr (moderate), with about 5.9 inches (high) available water capacity. The flooding frequency for this component is frequent. The ponding hazard is none. The minimum depth to a seasonal water table, when present, is about 24 inches.

**Rippowam** This component occurs on river valley, drainageway, depression, flood plain landforms. The parent material consists of alluvium. The slope ranges from 0 to 3 percent and the runoff class is very low. The depth to a restrictive feature is greater than 60 inches. The drainage class is poorly drained. The slowest permeability within 60 inches is about 0.57 in/hr (moderate), with about 6.2 inches (high) available water capacity. The flooding frequency for this component is frequent. The ponding hazard is none. The minimum depth to a seasonal water table, when present, is about 9 inches.

#### **Saco soils**

This component occurs on drainageway, depression, river valley, flood plain landforms. The parent material consists of alluvium. The slope ranges from 0 to 2 percent and the runoff class is low. The depth to a restrictive feature is greater than 60 inches. The drainage class is very poorly drained. The slowest permeability within 60 inches is about 0.57 in/hr (moderate), with about 10.1 inches (high) available water capacity. The flooding frequency for this component is frequent. The ponding hazard is none. The minimum depth to a seasonal water table, when present, is about 3 inches.

**Dumps** Dumps are areas of smoothed or uneven accumulations or piles of waste rock and general refuse. The slope ranges from 0 to 15 percent and the runoff class is very low.

**Urban Land** Urban land is land mostly covered by streets, parking lots, buildings, and other structures of urban areas. The slope ranges from 15 to 25 percent and the runoff class is very high.

**Table 2.** Select properties of predominant North End Peninsula soils

Soil	Slope (%)	Hydrologic Group	Drainage	Runoff	Depth to Restrictive Feature	Erosion Factors	Ponding (Frequency/ Duration)	Flooding (Frequency/ Duration)	Depth to Seasonal High Water Table
<i>Catden</i>	0-2	D	Very Poorly	Negligible	>60"	Low	Frequent/ Long	Rare/Very Brief	4"
<i>Freetown</i>	0-2	D	Very Poorly	Negligible	>60"	Low	Frequent/ Long	Rare/Very Brief	4"
<i>Saco</i>	0-2	D	Very Poorly	Low	>60"	Low	None	Frequent/ Brief <sup>1</sup>	3"
<i>Rippowam</i>	0-3	D	Poorly	Very Low	>60"	Low to Moderate	None	Frequent/ Brief <sup>1</sup>	9"
Pootatuck	0-3	B	Moderately Well	Very Low	>60"	Moderate	None	Frequent/ Brief	24"
Wethersfield	15-25	C	Well	Medium	20-40" (hardpan)	Moderate to High	None	None	24"
Dumps	0-15	—	—	Very Low	—	—	None	None	—
Urban Land	15-25	—	—	Very High	—	—	None	None	—

<sup>1</sup>October through May, no flooding expected June to September

**Table 3.** Select limitations, hazards, and suitability of predominant North End Peninsula soils

Soil	Limitations on Paths & Trails	Limitation on Off-Road Vehicle Trails	Limitation on Camps, Picnic Areas, & Playgrounds	Hazard of Soil Rutting	Suitability for Natural Surface Roads
<i>Catden</i>	Very <sup>1,3,5</sup>	Very <sup>1,3,5</sup>	Very <sup>1,2,3,5</sup>	Severe <sup>6</sup>	Poor <sup>3,6,7</sup>
<i>Freetown</i>	Very <sup>1,2,5</sup>	Very <sup>1,2,5</sup>	Very <sup>1,2,3,5</sup>	Severe <sup>7</sup>	Poor <sup>3,6,7</sup>
<i>Saco</i>	Very <sup>1,2</sup>	Very <sup>1,2</sup>	Very <sup>1,2</sup>	Severe <sup>7</sup>	Poor <sup>2,6,7</sup>
<i>Rippowam</i>	Very <sup>1,2</sup>	Very <sup>1,2</sup>	Very <sup>1,2</sup>	Moderate <sup>7</sup>	Poor <sup>2,6</sup>
Pootatuck	Somewhat <sup>2</sup>	Somewhat <sup>2</sup>	Very <sup>1,2</sup>	Moderate <sup>7</sup>	Poor <sup>2</sup>
Wethersfield	Somewhat <sup>4</sup>	Not	Very <sup>1,4</sup>	Severe <sup>7</sup>	Poor <sup>4,7</sup>

**Limiting Features**

- <sup>1</sup> Depth to saturated zone
- <sup>2</sup> Flooding
- <sup>3</sup> Ponding
- <sup>4</sup> Slope
- <sup>5</sup> Organic Matter Content
- <sup>6</sup> Wetness
- <sup>7</sup> Strength

## *Proposed Activities*

### **Walking Trail**

A walking trail that both circumnavigates and climbs to the top of the landfill is proposed. Potential concerns restricting either the development or use of a trail system include the seasonally saturated nature of floodplain and muck soils, the possibility of seasonal flooding at the lower elevations along the base of the landfill, and a moderate erosion potential due to slope and soil type.

Additionally, some areas of the landfill's side slopes were observed to be slumping or failing slightly and there was evidence of water ponding in a small depression on top of the landfill. Careful consideration to where and how the trail system is established and maintained will help minimize any potential impacts due to adverse soil conditions.

**Recommendations** (see guidance documents in the Appendix)

1. Mark the approved trail network in a clear and comprehensive manner to discourage cross cutting and off trail recreation.
2. The lower trail should be located at an elevation above the 100-year flood zone.
3. Use of the trail should be restricted if/when soils are seasonally saturated or flooded.
4. Trail areas that are chronically wet should be rerouted if possible. Otherwise, spanning structures or cross drainage can be used to help improve trail condition.
5. Establish the trail to the top of the landfill to transverse across the slope, e.g., with switch-backs to climb the grade, to minimize erosion.
6. To avoid erosive flows on trails, cross pitch them at 3-4% to quickly drain surface runoff downslope off the trail. Cross sloped trails are the easiest to construct when the trail traverses the natural grade.
7. Provide selective access to the Coginchaug and Mattabesset rivers only in areas where banks are stabilized and vegetated. Restrict recreational access in areas where banks are obviously failing, vegetation is sparse, or there is active bank scour/undercutting.
8. Consider posting "no entry - conservation area" signs in areas with critical slopes or where there is observed slumping or erosion.
9. Minimize concentrated stormwater flows on steep trail sections by using water bars at controlled points to direct excess runoff to stable vegetated areas on the side slope. In very steep areas discharging flows to a small riprap splash pad or stone check dam may be necessary.
10. If portions of the trail are to be surfaced, consideration should be given to using a pervious material to encourage infiltration of rainfall and snowmelt (e.g., geo-grid system, free draining gravel, gravel-pave, or geotextile based).



**Top of the landfill looking north.**



### Access and Parking

*Access to the site is from North Main Street through the recycling transfer station. Conflicts between activities at the transfer station and recreational users will need to be considered. Parking for the recreational trail as well as the kayak/canoe launch will also need to be provided.*

### Recommendations

1. Signs should clearly identify approved parking areas and natural areas to remain undisturbed.
2. Pervious surfacing materials should be considered for parking areas and any new access drives in order to encourage stormwater infiltration.
3. Drainage from parking areas and access drives should not discharge directly into either river or inland wetlands on-site.
4. Access to trails and the launch site should not conflict with transfer station activities. A win-win solution should be sought that will minimize conflicts and improve environmental conditions through implementation of best management practices that will also reduce and control pollution.



**View of landfill behind transfer station.**

### Kayak and Canoe Launch

*A car-top kayak and canoe launch has been proposed. There are two potential locations for the launch site, to the east of the landfill on the Mattabesset River or to the west on the Coginchaug River. Areas with discolored flows were observed in the vicinity of the proposed launch site on the Mattabesset, and a number of known seeps are also present on this side of the landfill. Based on these observations, and the broad floodplain topography of the Mattabesset at the potential launch site, the alternative location on the Coginchaug River should be explored first.*

### Recommendations

1. Information outlining the rules for use of the launch should be clearly posted.
2. Due to the muck nature of the soils associated with the Coginchaug River in the vicinity of the proposed launch, a stabilized surface should be provided that will allow boaters to enter and leave the river at a variety of high/low water conditions.
3. The launch areas should be designed to prevent bank erosion in both the upstream and downstream direction, i.e., flows/flood forces should not be deflected to nearby banks.



**Possible launch sites on the Mattabesset (above) and Coginchaug (below).**



## WETLAND REVIEW

The Team visited the site in December 2005 when there was a little snow on the ground in the sunny areas and more snow present in the wooded locations. Sheet ice occurred on portions of the dirt roadways. This section assesses the impacts of the two possible boat launch areas.

### Site Description

As can be seen in the comparison photographs below, the geography of the area, and the accompanying wetland regimes, have been greatly altered in the last several decades due to the establishment and growth of the landfill.



Figure 1- the April 1934 aerial photograph on the left and the same area depicted in 1990 show the massive amount of alteration to the landscape that the landfill had.

The Team walked much of the property. Initially the Team traveled from the parking area near the buildings over to the bottom of the left hand meander where the Mattabesset River forms a "W". From there the Team walked over the top of the mound to nearly the north tip of the peninsula. The Team then bushwhacked west to the Cuginchaug River on the west side of the landfill. From there the group followed a one lane, unpaved service road south through the

active bulky waste area back to our cars parked just west of the buildings by the railroad tracks.

All but the southern boundary of the landfill area is abutted by watercourses. This peninsula juts out into the massive floodplain formed by the confluence of the Coginchaug and Mattabeset rivers. The Coginchaug River drains approximately 39+ square miles of land above this point. It flows north past the west side of the landfill to its confluence with the Mattabeset River. The Mattabeset continues its miles-long flow past the confluence near the north end of the peninsula generally east and then south along the landfill before bending east again and emptying into the Connecticut River. It drains roughly 70 square miles before emptying into the Connecticut River.

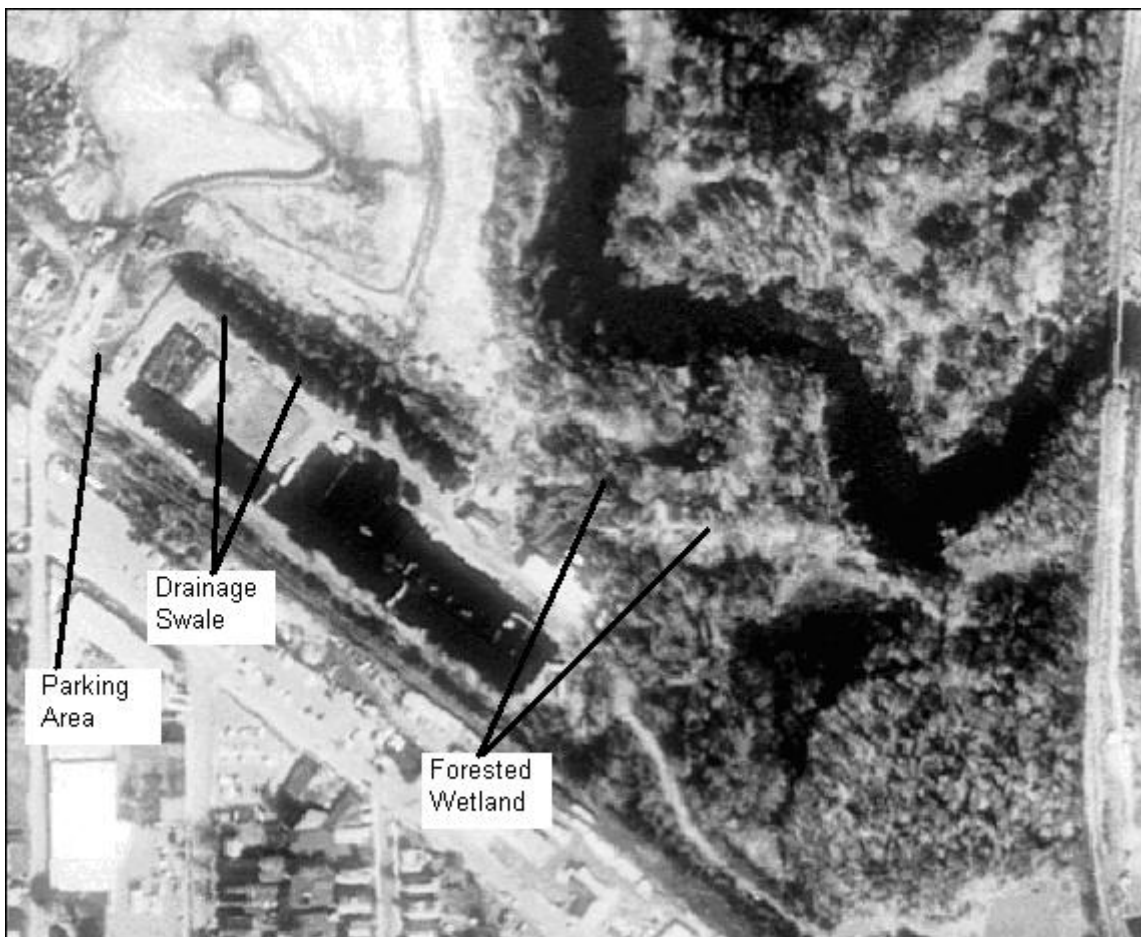

Figure 2 - The drainage swale depicted above empties into the forested wetland of this floodplain. The stream was actively flowing, not frozen.

Of the wetland areas the Team visited that were likely to be impacted by any future activity, both are waterside locations which are likely prone to various elevations of flooding. The first of these is the forested wetlands labeled in Figure 2. There was some snow on the ground here, but as can be seen in Figure 3, there were also areas that were snow free and the ground was exposed.

In the areas that were free of snow, the soil could be seen as reddish-brown in color. There was some surface movement of water over the open ground, and below the ice layer, as the water moved gradually downslope toward the river (Figure 4).



*Figure 3 - This is where the drainage swale empties onto the floodplain. A colorful iron bacteria film was present along the shoreline. Iron bacteria is sometimes visually confused with oil floating on water; but the iron bacteria “breaks” when disturbed, while the oil swirls.*

The second site to be potentially impacted is on the floodplain west of the landfill where paddlers would launch into the Coginchaug. Both of the potential sites are forested wetlands with mature growth dominated by maple trees (*Acer* spp.). Both the east and west potential launch locations are well shaded with what is likely a 70+ percent canopy cover. The shrub layer is, for the most part, nonexistent. The herb layer is dominated by grasses that grow where there is slightly elevated, and thus better drained, micro relief.

## Discussion

The largest wetland area with potential impacts is the Mattabesset River forested wetland. This wetland area measures roughly 13 acres in size. It is dominated by two soils types: Rippowam and Pootatuck. The exposed soils in this floodplain were red-brown in color. Open water had a rainbow colored film of iron bacteria near the shoreline edges. Both the soil color and the bacteria are indicators of elevated iron levels

in the soils. Soils mapping done by the USDA Natural Resources Conservation Service has the minimum limit of three acres in size for any mapped soil. Thus, other soil types can occur in pockets of a three acre mapped soil and go unrecognized. That is likely the case with these iron rich soils. Only one red alluvial soil is mapped in Connecticut. This is the Bash soil which has developed in alluvium derived from reddish sandstone, siltstone and shale (in this case reddish brown Portland arkose - brownstone). Thus, the red coloration of the soil and the iron bacteria on the water are natural phenomenon due to the high iron content of the parent material from which the soil formed. (See Figure 4.)



*Figure 4 - Red brown soils can be seen in the foreground with runoff occurring under the thin layer of surface ice.*

The Coginchaug River abuts the property along the west side as can be seen below in this 2004 image of the area (Figure 5). It is clear from the photograph that much of this floodplain was in flood condition when this photo was taken. The half circle, arc-like indentation along the west side of the peninsula is paralleled by a single lane road, just to the east of the tree line. This road would be the general vehicle access to the rear carry-in launch site. The image also provides the opportunity to visualize the variable 60 - 80 foot wide riparian buffer that lies between the river and the road.

## **Impacts**

The greatest specific wetland impact involves carry-in path(s) that will access the proposed launch (es). These will be the pathways from the parking areas to the actual put-in sites. Both sides of the landfill offer a location that would necessitate



travel across the forested wetland/riparian area to reach the river. Compaction of the floodplain soils would likely be the biggest impact (assuming there is no removal of existing vegetation, excavation or construction). But that compaction would be weighted against 1.) the prospect of gaining public access to these locations that might not otherwise be visited, and 2.) an aesthetic awareness of the river complex.

Any use, by default, will have some level of impact. The goal in these locations is to minimize impacts by using the most environmentally sensitive approaches and launch configurations.

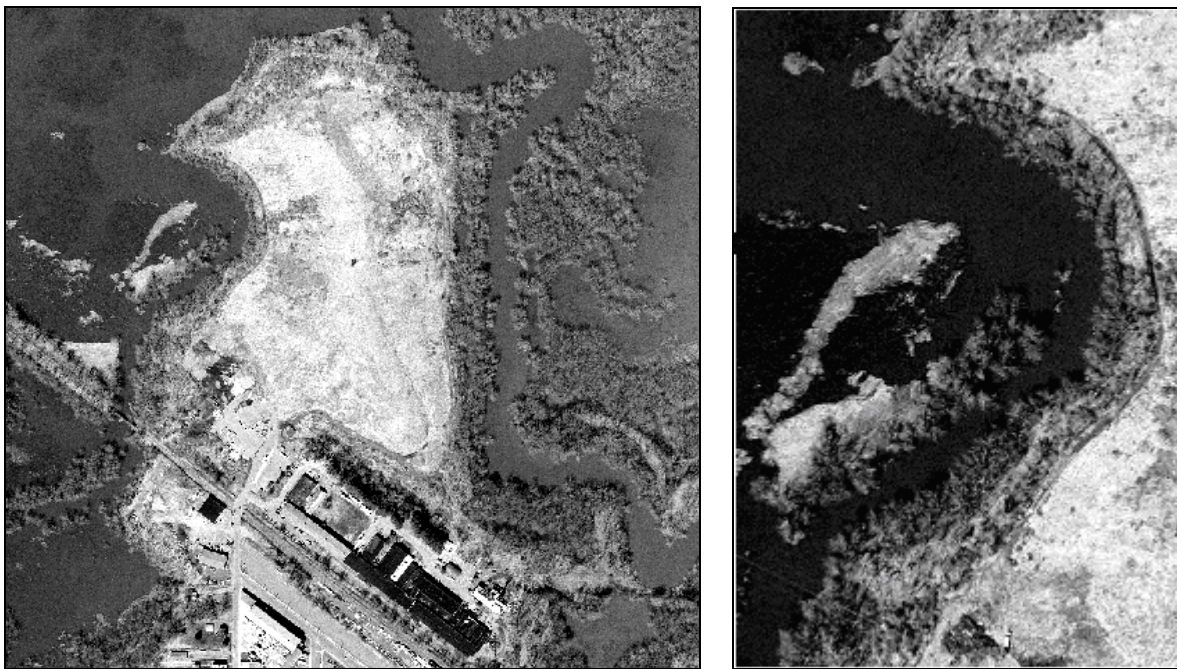

Figure 5 - this 2004 image shows the landfill site in its entirety with a closeup of the west side indentation. The dark color, single lane road is visible to the right of the tree line in the right hand image.

On the east side, the Team observed active drainage across the floodplain. An unnamed stream flows out of the drainage swale and across this wooded area. A road parallels the swale to the bottom of the slope, however, it should be made clear that **boaters must be able to carry their boats and gear from the parking area to the launch area. All parking**

**areas will have to be designated and well marked.** The launch into the Mattabesset would be the handiest access to the general entrance of the landfill grounds.

Any approach to the watercourse should be located as close to the level of the water as possible. The Team saw that the Mattabesset forms a "W" in its meandering. The two bottom points of the "W" are undercut by the river and exhibit the longest drop to the water from the shore. The indentation between the two lower points of the "W" would have the most level land-to-water access. One of the steep drops to the water at the undercut areas is seen in Figure 5.

In addition, the Mattabesset launch is closest to the entrance, and might yield the biggest 'bang' for the low budget buck in this early planning. It also has the advantage of proximity to the roadway that leads to the top of the mound and offers the spectacular views. It would mean a carry of about 300 yards however, unless a small parking area was planned at the bottom of the road the parallels the swale.



Figure 6 - this is a view looking down slope into the Mattabesset. Notice the 5 or 6 inches of concrete pipe emerging from the bottom of the bluff. The discharge from the pipe, though small, was constant and fell with sufficient energy to form a little plunge pool which kept the water open and ice free.

The prospect of a launch along the Coginchaug is more involved. After crossing the railroad tracks to enter the site, the three tenths-of-a-mile drive brings visitors *through* the landfill facility and into an isolated area towards the rear of the property. The field walk showed this single lane road was drivable and probably able to yield four to six parking spaces as it now exists. The carry in from the parked cars, being about 60 feet, would be much shorter than at the Mattabesset.

## Summary

The launch into the Mattabesset River seems the easiest and most straightforward launch to begin the project. In its full scope the project seems ambitious, but this first 'phase' seems quite logical. Depending on how it is measured the main stem of the Mattabesset flows  $\pm 12$  miles through suburbia, past farmlands and into floodplain. There is little access to the river and, as a result, the public has little chance to view and recreate on/with this great water resource. This project offers an opportunity to do just that.





Figure 7 - this is the view from the single lane road through the trees to the Coginchaug River. This is the distance of the carry-in for the potential west side launch.

## Other Points

- This is an ambitious proposal, but possible. The Jonah Center's theme to make use of this otherwise abandoned property is inspiring and takes aim at many environmental issues in its broad scope. From methane recovery to active and passive recreation, there are opportunities for remarkable viewscapes, hiking, birding, paddling and education in general.
- Any proposed trail work should minimize vegetation clearing and soil moving. Erosion and sediment controls in such proximity to wetlands and watercourses would be a cause for concern.
- It was an interesting note that this landfill site provided members of the Team with wildlife viewing opportunities not frequently encountered. An opossum was



seen in a tree, a field mouse or vole was spotted running through the grass and deer sign was frequent. The diversity of small to large wildlife speaks to the landfill's varied habitat, sufficient food sources and the likelihood that birds of prey frequent the area. There are no doubt birding opportunities that abound in season.

- One note of concern was the isolation of the Coginchaug River launch. The unaesthetic drive through, or in close proximity to, the bulky waste recovery area led to the potential parking site in the northwest part of the property. That location is only 350 feet from the vagabond camp the Team visited near the north end of the peninsula. Whether the camp is the work of boaters, junkies, homeless, or just long term camping, the question of security in that remote part of the peninsula will have to be addressed.
- There may be other forested wetland pockets in various locations around the landfill. This report only addresses the two potential carry-in boat launches.
- A possibility that was discussed during the pre-field walk meeting was that of connectivity southward from the landfill, along the Coginchaug River, to Veterans Park. Following the river it is 1.5 miles from the railroad tracks at the landfill entrance to Veterans Park. Any plan that puts walkers and/or paddlers along the river nearly ensures enhanced water quality over time. It is easy to degrade a resource the public does not see, it is much harder to impact that same resource when it is in the public eye and the public's use. Currently the DEP maps the water quality of the Coginchaug as level "B". This is on a rating scale of "AA" being the best, "A" being next, then "B", "C", and finally "D". The full text of the DEP's *Water Quality Standards and Criteria* can be found on the web at: <http://www.dep.state.ct.us/wtr/wq/wqs.pdf>

## STORMWATER MANAGEMENT

If soil disturbance related to the construction of the walking trail exceeds five acres, the project will be regulated by the Department of Environmental Protection's General Permit for the Discharge of Stormwater and Dewatering Wastewaters Associated with Construction Activities ("the construction general permit"). For disturbance areas between 1 and 5 acres, registration under the construction general permit will not be required provided the project receives local review and written approval of its erosion and sediment control plan, and follows the 2002 Connecticut Guidelines for Soil Erosion and Sediment Control ("Guidelines").

If the five acre disturbance threshold is exceeded, the following comments discuss the requirements of the construction general permit, many of which overlap with local requirements and the Guidelines. The owner or developer of the site must register this site with the DEP thirty days prior to the commencement of construction activity. Additionally, a Pollution Control Plan ("the PCP") must be prepared and kept on site during the entire life of the construction project.

The PCP must include a site map as described in Section 6(b)(6)(A) of the construction general permit and a copy of the erosion and sedimentation (E & S) control plan for the site. An E & S plan which has been approved by the City of Middletown in conjunction with the DEP Inland Water Resources Division (IWRD) and the local Soil and Water Conservation District may be included in the PCP. The PCP and site map must include specifics on controls that will be used during each phase of construction, pursuant to Section 6(b)(6)(B) of the construction general permit. Specific site maps and controls must be described in the PCP, as well as construction details for each control used. The construction general permit requires that the plan shall ensure and demonstrate compliance with "the Guidelines." The Plan must be flexible to account for adjustment of controls as necessary to meet field conditions.

The PCP must demonstrate that the post-construction stormwater treatment system has been designed with a goal of 80% removal of total suspended solids, pursuant to Section 6(b)(6)(C)(iii)(1) of the construction general permit. Such measures may include, but are not limited to, stormwater detention basins, stormwater retention basins, swirl concentrator technology structures (such as Vortech, Downstream Defender, Stormceptor, Stormtreat, or similar), vegetated swales, deep catch basin sumps (4'+) and stormwater infiltration devices. The PCP must also discuss the installation of velocity dissipation devices at all discharge locations as a post construction stormwater management measure. A detail of proposed measures as well as drainage calculations must be provided. If site conditions allow, DEP recommends the installation of retention or detention basins because of maintenance, cost, and efficiency considerations.

The elimination of point sources through the use of sheet flow, of level spreaders, or of curb elimination should also be evaluated.

The construction general permit (Section 6(b)(6)(D)) requires inspections of all areas at least once every seven calendar days and after every storm of 0.1 inches or greater. The PCP must also allow for the inspector to require additional control measures if the inspection finds them necessary, and should note the qualifications of personnel doing the inspections. Since the proposed site has areas with steep slopes and numerous wetland areas requiring protection, ongoing inspections and adjustments of controls will be an important aspect of this project. Additionally, the PCP must include monthly inspections of stabilized areas for at least three months following stabilization.

The following are specific comments based on observations made during the December 22, 2005 site visit, review of the conceptual site plan provided with the ERT notification package on December 8, 2005, and the Final Site Inspection Prioritization Report dated September 8, 1997:

- The minimization of soil disturbance to install the trail is strongly recommended to reduce the pollution potential from the liberation of pollutants in the soil matrix.
- To promote infiltration and the sheet flow of stormwater, the utilization of a pervious or semi-pervious material for the trail surface is recommended.
- A plan for managing existing and future leachate seeps and erosion areas must be prepared and implemented as part of the landfill closure plan and as part of the trail construction project.
- Management of activities at the transfer station must be improved as they are in violation of the requirements of the General Permit for the Discharge of Stormwater Associated with Industrial Activity. Specifically, the storage of uncovered waste piles (metal, soil/ construction debris, street sweepings and/ or catch basin cleanings) in the vicinity of the Coginchaug River is of concern. Additionally, the storage of oil and antifreeze with inadequate secondary containment and the presence of uncovered waste dumpsters/ rolloffs (when inactive) are problematic.
- In order to reduce erosion potential, DEP recommends that construction activities be phased to the maximum extent possible so that unstable areas are minimized. The construction general permit also requires that any inactive area left disturbed for over 7 days be temporarily stabilized. Areas left disturbed over 30 days must be temporarily seeded.

- For slopes which are steeper than 4 horizontal to 1 vertical, DEP strongly recommends the use of erosion control matting.
- Any areas left disturbed beyond the planting season (after October 1) must be stabilized for the winter. Stabilization should be in the form of properly selected erosion control matting or a spray-on "soil cement" type of armor mulch.

## FISHERIES RESOURCES

The Coginchaug River confluences with the Mattabessett River on the north side of the Middletown landfill. The marshes in this area are referred to as the Cromwell Meadows. Many freshwater finfish, which reside in the mainstem of the Connecticut River, would be expected to seasonally inhabit these aquatic resources or pass through this area to access upstream fish habitats. Cromwell Meadows are a known important spawning and nursery area for the Connecticut River northern pike population.



*Northern Pike*

Based upon data collected from trap nets in the mid 1990's, the following resident species can be found in this region: channel catfish, white catfish, brown bullhead, common carp, yellow perch, white perch, chain pickerel, bluegill, pumpkinseed, redbreast sunfish, black crappie and largemouth bass. These waters seasonally harbor many species of diadromous fish, primarily blueback herring, alewife and American eel. To learn more about fishes that live in Connecticut waters, the following publication may be of interest: "Freshwater Fishes of Connecticut" by Walter R. Whitworth (Whitworth 1996).

Surface water quality of the Coginchaug River adjacent to the landfill is classified by the Connecticut Department of Environmental Protection as Class B. Designated uses of Class B waters are as follows: fish and wildlife habitat, recreational use, agricultural and industrial supply and other legitimate uses including navigation.

Surface water quality of the Mattabessett River is classified by the Connecticut Department of Environmental Protection as Class C/B. This designation means that the area is presently not meeting Class B water quality criteria or one or more designated uses. The future goal is to improve water quality to meet a Class B designation.

### Recommendations

1. The Coginchaug River and Mattabessett River and surrounding wetlands could serve as valuable ecological study areas for the general public and local school systems as well. The Jonah Center should consider installing interpretative signs along the trail system to explain the types and values of various river, wetland and upland habitats along with identifying local flora and fauna.

2. Any trail crossings within wetland habitats on the property should be accomplished with raised boardwalk or timber bridge structures to reduce erosion and sedimentation to nearby aquatic resources.
3. It appears that the more appropriate location for providing access for car-top boats, kayaks and canoes is at the proposed location on the Mattabessett River, at the southeast side of the landfill. A location on the Coginchaug River would possible result in more disturbance to riparian areas and also create more possible conflicts with the public driving or walking through the active portion of the Middletown Transfer Station. Regarding the Mattabessett River location, efforts should be made to minimize the amount of vegetative removal/clearing and placement of fill in the floodplain to create this formal access area. This location has suitable room for a formal parking lot. The streambank on the Mattabessett River is somewhat steep in the proposed location. It will have to be regraded and sloped back to provide a more gradual ramp and transition into the river.
4. The Jonah Center may also want to consider providing fishing access in the form of a fishing pier for handicapped anglers. If there is further interest in the pursuit of fishing access, the Team's fisheries biologist can provide more specifics relative to possible locations and design examples of fishing piers constructed on State property.

### **Literature Cited**

Whitworth, W.R. 1996. Freshwater fishes of Connecticut. Connecticut Geologic and Natural History Survey Bulletin No. 114. Hartford, CT. 243p.

## THE NATURAL DIVERSITY DATA BASE

The Natural Diversity Data Base maps and files have been reviewed regarding the project area. According to our information, there are records for State Endangered *Botaurus lentiginosus* (American Bittern) from Boggy Meadows.



The American Bittern is a secretive bird that nests in marsh complexes. Bitterns are most susceptible to human disturbance during the breeding season. If work is conducted outside of the breeding season (April through July), and standard protocols for protection of wetlands are followed and maintained during the course of the project, potential impacts to these species will be reduced. Any vegetation screen along the marsh should be allowed and encouraged to help secretive wetland species, like the American Bittern, nest. The Wildlife

Division recommends that the work not be done between April and August to eliminate disturbance to the nesting bitterns.

The Wildlife Division has additional concerns about two federally threatened wildlife species to the north of this project that may be impacted by the kayakers; the Bald Eagle (*Haliaeetus leucophalus*) and the Puritan Tiger Beetle (*Cicindela puritana*). The bald eagle and Puritan tiger beetle are state endangered and federally threatened species. "Take" is defined in the Endangered Species Act as harassing, harming, pursuing, hunting, shooting, wounding, killing, trapping, capturing, or collecting listed wildlife species; attempting to engage in such conduct or soliciting or causing such acts to be committed. "Harm" is defined as significantly impairing essential behavioral patterns including breeding, feeding, or sheltering. "Harass" is defined as an intentional or negligent act or omission which creates the likelihood of injury to wildlife by annoying it to such an extent as to significantly disrupt normal behavior patterns which include but are not limited to, breeding, feeding, or sheltering.

The Wildlife Division is interested to work with the City and the proponents of the project to avoid "take" of bald eagles and Puritan tiger beetles under Section 9 of the Endangered Species Act. The U. S. Fish and Wildlife Service (USFWS) Regional Field Office should be contacted about this project because of possible detrimental effects to eagles and Puritan tiger beetles. The Wildlife Division will be happy to assist you and the USFWS in the consultation process. It is recommended that you contact the USFWS (Susi VonOettingen, USFWS, 70 Commercial St., Suite 300, Concord, NH 03301-5087, (603-223-2541). Please be advised that formal consultation with the USFWS may be required to avoid adverse effects. Formal consultation with the USFWS, as described under Section 7 of the Endangered Species Act, is a process by which the Service determines

whether adverse effect is likely to jeopardize the continued existence of a species or cause "take."

Please be advised that if state permits are required for this project then additional evaluation of the proposal by the DEP Wildlife Division and the US Fish and Wildlife Service is requested. The Wildlife Division has not made an on-site inspection of the project area nor been provided with details or a timetable of the work to be done. Consultation with the Wildlife Division should not be substituted for on-site surveys required for environmental assessments.

Natural Diversity Data Base information includes all information regarding critical biological resources available to us at the time of the request. This information is a compilation of data collected over the years by the Natural Resources Center's Geological and Natural History Survey and cooperating units of DEP, private conservation groups and the scientific community. This information is not necessarily the result of comprehensive or site-specific field investigations. Consultations with the Data Base should not be substitutes for on-site surveys required for environmental assessments. Current research projects and new contributors continue to identify additional populations of species and locations of habitats of concern, as well as, enhance existing data. Such new information is incorporated into the Data Base as it becomes available.

This is a preliminary review and not a final determination. A more detailed review may be conducted as part of any subsequent environmental permit applications submitted to DEP for the proposed site.

*(The DEP Wildlife Fact Sheets for the American Bittern, Puritan Tiger Beetle and the Bald Eagle may be found in the Appendix.)*



## RECREATION PLANNING REVIEW

The subject of the ERT review is a 45 acre site at the confluence of the Coginchaug and Mattabessett Rivers in northeastern Middletown. Within the site are located the 27 acre closed and capped landfill and the active municipal recycling center. Reuse of the property (minus the Recycling Center) as an eventual environmental education center has been proposed by the non-profit Jonah Center for Earth and Art.



Originally a floodplain wetland, the area has been transformed into a +100 foot high hill, edged by a remaining wetland fringe on its eastern side. Dominating the local landscape and especially the view over the Cromwell Meadows, the landform clearly has scenic and recreational potential. It is largely grass-covered, although some low brush has begun to appear. Although snow cover at the time of the site visit limited inspection, it appears that the

vegetative cover is largely intact and with minor erosion problems.

The major site reuse issue involves public health and aesthetic considerations concerning possible human activity. Diana Lane's 8/31/05 memo seems to indicate that soil and water contamination levels generally were not a significant factor with the possible exception of the soil sampling results on the northeast side of the landfill (Sample SS-05). Methane leaks occur in the same northwest side of the landfill (and a methane smell was also experienced along the road along the southern edge of the landfill). In addition, leachate was noted along the eastern side. Although this reviewer is not qualified to evaluate a major reuse effort involving structures and regular, on-going on-site public occupancy, it appears that casual, low intensity public visitation should not be a public health concern. Nevertheless, the present unattractive nature of the recycling center at the entrance to the area plus whatever landfill aromas or visual blights which may persist could have negative impact on likely public usage.



With these considerations in mind, evaluation of the reuse proposal can be made. Basically Phase 1 would consist of a walking trail around the landfill (partially on former roadways and above expected floodwater level), and a second trail to the summit along a former roadway and perhaps down the northwest slope to the loop trail, and a kayak launch site near the southeast corner of the tract (service by perhaps 6+ place parking lot). All of these seem to be feasible and involving minimal cost. Furthermore, the vista from the summit would be a major attraction. However, the proposed downhill trail on the landfill proper should be carefully sited and designed to avoid erosion and siltation impact. A more serious problem involves the recognized need to provide a separate entranceway between the recycling center on the west and the city-owned and leased building on the east.

Potential linkages with other municipal holdings were mentioned in passing, with Roosevelt Park at the end of Bridge Street an obvious prospect. Some discussion also occurred about possible additional city acquisition along the Coginchaug River between Veteran's Park and the landfill, potentially creating a riverine greenbelt corridor. However, physical constraints such as an active railroad and wet floodplain soils appear to rule out a possible trail connecting the two areas.

## TRAFFIC CONSIDERATIONS

There are no site or parking plans at this time, but based on the trip generation manual it would not seem to generate much local traffic. A state park generates approximately 0.6 trips per acre, a city park 1.5 trips per acre, and a county park 2.3 trips per acre. Using the highest trip figure, the trail would only increase traffic by about 100 trips per day, and would have little effect of the adjacent streets. The easiest access to the site from RT 66 eastbound would seem to be from North Main Street with Johnson to Spring Street egress and vice versa from RT 66 westbound, but with so many connector streets it is difficult to tell. It would seem that most traffic from RT 3 would access the site by Prospect and Johnson Streets. Based on this information this reviewer does not think there would be a significant impact to the local traffic flow.

## APPENDIX

### Trail Creation and Maintenance Documents

Trail Shorts: A cursory look at trail maintenance  
Washington Trails Association Drainage Structures  
Geosynthetics for Trails in Wet Areas

### Connecticut Department of Environmental Protection

#### Wildlife in Connecticut – Endangered and Threatened Species Series

American Bittern  
Puritan Tiger Beetle  
Bald Eagle

This document is available at <http://www.foothill.net/fta/work/maintnotes.html>



## TRAIL SHORTS

### A Cursory Look at Trail Maintenance

## INTRODUCTION

This document focuses on wilderness trails only and is intended to be used as a reference by trail maintenance crews. If you have questions about the contents, please do not hesitate to contact Clay Phillips at the Southern Service Center of California State Parks at (619) 220-5303.

Trail construction and maintenance is an inexact science with many variables. Much depends on the location of the trail, the soil, the climate, and the types of uses. However, there are certain general guidelines which, if adhered to, will prevent most trail deterioration and minimize maintenance costs.

## Trail Problems

Trail users may not be able to articulate what a "perfect" trail looks like, but almost everyone can list the characteristics of a "bad" trail:

1. **Deep Trenching** - The trail is sunken such that hikers feel like they're walking in the bottom half of a pipe and equestrians drag their spurs.
2. **Widening** - The trail has widened from a single or double track to an unsightly wilderness "freeway" of multiple parallel tracks, all trenched to a different degree.
3. **Short Cuts** - Knowing that the shortest distance between two points is a straight line, users create a web of trails, most of which are steep and erosive.
4. **Tripping Hazards** - Regular use and erosion ultimately expose tree roots and rocks.
5. **Steepness** - If a trail is too steep over a long distance one of two things will happen: either people won't use it, or users will not enjoy their excursion.
6. **Impact to Natural / Cultural Resources** - Erosive trails and multiple trails compound the impact that trails have on rare plants and on archaeological sites.

## Causes

All of these problems can be tied to one or more of the following three causes:

1. **Water** is the foremost cause of trail problems. The movement of water causes erosion and deep trenches. It also exposes tripping hazards.
2. **Poor Initial Trail Design** can rarely be overcome, even by regular maintenance.
3. **Inadequate or Inappropriate Maintenance** wastes valuable crew time and can sometimes increase trail problems.

## DESIGNING FOR TRAIL MAINTENANCE

**Ultimately, the most influential component of trail maintenance is the original trail design / alignment.** A well-designed trail will be easier to maintain, will deteriorate more slowly and will be more pleasant to use. On the other hand, a poorly-designed trail is difficult to maintain, deteriorates quickly and, once you lose it, there's not much that can be done to restore it. In addition, a poorly designed trail will always be less pleasant to hike or ride.

### Elements of a Well-Designed Trail

There are many factors which go into a well designed trail; here we will only look at the elements required from a maintenance perspective.

#### 1. Gradient

Generally, the linear gradient of a trail should be less than 10%. The term "gradient" refers to the ratio of the rise over the run. In other words, an elevation gain of 2 feet in 20 horizontal feet represents a 10% gradient.

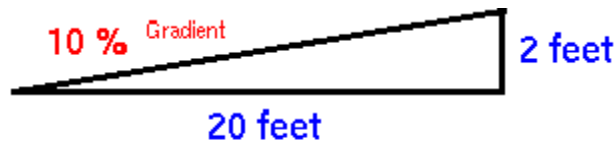

Figure 1

Ten percent is a good standard, but circumstance may warrant a greater or lesser gradient.

In highly erosive, sandy soils, a 5% slope may be excessive. Granitic soils are more forgiving and can allow long sections of trail to be constructed at 13 to 15%. It is best to look at existing trail conditions and measure gradients to determine what maximum gradient works best in each unique condition. However, it should be noted that trails less than 10% are far more comfortable to hike and ride. The soils may allow for a trail that exceeds 10%, but the users might not!

#### 2. Relationship to Existing Contours

In map jargon, a contour is a line of points that are at the same elevation. If you walk precisely parallel to a contour, you are walking at a level (0%) grade. If you walk perpendicular to a contour, you are walking either straight uphill or straight downhill. A well-designed trail is laid out to traverse a hillside, closer to parallel than perpendicular to the contours.

The figure below shows two proposed trail routes to the top of the hill. Although Trail A stays within a gradient of 10%, it is the poorer route because it travels perpendicular to the contours. When a trail runs perpendicular to the contours, water runs down the middle of the trail, causing trenching, even at a 10% gradient. The only way to get water off the trail is for the route to **traverse** the natural slope (Trail B), because then there is always a lower side of the trail.

When there is a lower side of the trail, it becomes a simple matter to redirect water across and off the trail, rather than allowing it to cut a channel down the trail's centerline.

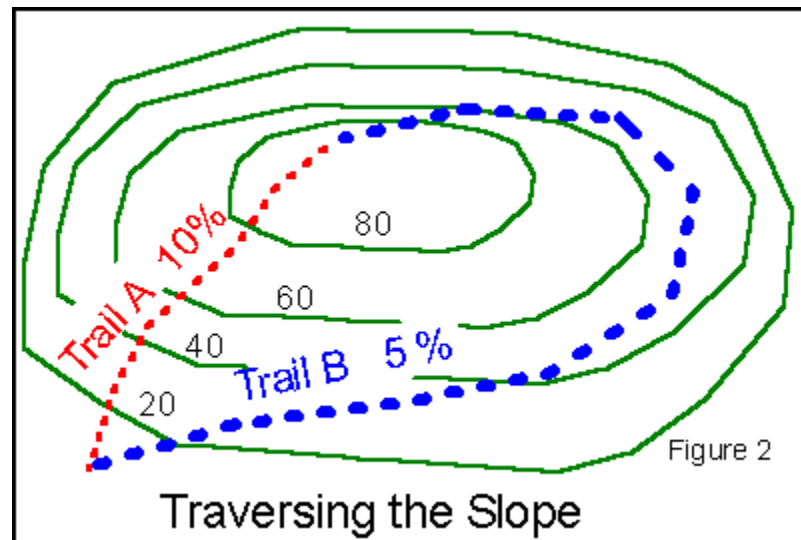

### 3. Outslope

A well-designed trail should be constructed to have a 3% to 4% cross-slope to get the water off the trail as soon as possible. This explains why it is difficult to construct an effective trail in a flat meadow. You can not merely cut out sod and call it a finished trail. It will always be easiest to construct an outsloped trail if the original trail alignment traverses the natural slope as in Trail B, above.

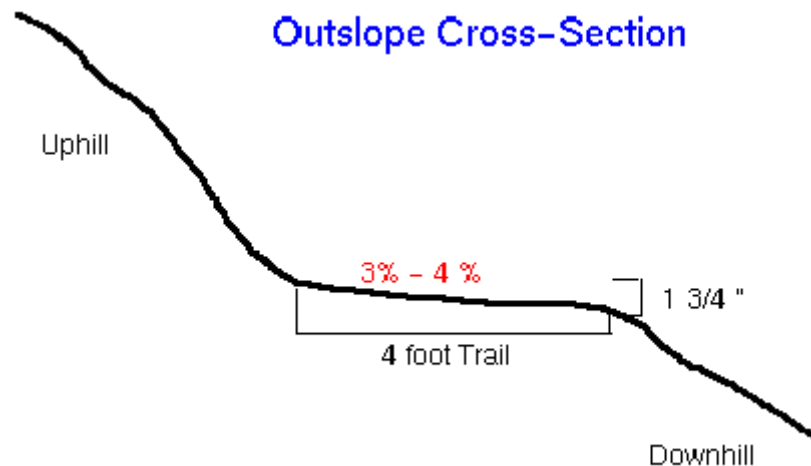

### 4. Avoid Switchbacks

A "switchback" is any place where the alignment of a trail traverses a slope in one direction and then abruptly "switches back" toward the opposite direction. Switchbacks are often used to run a trail up a steep slope in a constrained location. Although switchbacks are often the only solution to the problems of rock outcrops

and steep slopes, they should be avoided where possible. Unless they are perfectly designed and constructed, switchbacks present an irresistible temptation to shortcut the trail and cause erosion over a web of indiscriminantly created volunteer routes.

### KEY ELEMENTS OF TRAIL MAINTENANCE

The first step of trail maintenance is to inspect the trail. When erosion problems are evident, the principle questions to ask are, **"Where is the water going and how can I get it off?"**

The following elements represent the primary "tools" to be used in the maintenance of trails. They are generally listed in priority order, but each has its own special application and purpose. Clearly, though, the first 3 (Maintaining the Outslope, Install and Maintain Water Bars, and Maintaining Drainage Dips) are far and away the most important.

### Maintaining the Outslope

This is the first order of business in trail maintenance. It is the simplest, but most labor intensive trail maintenance tool.

Normal trail use will build up a berm along the outside (downhill) edge of the trail (Stage 2 of figure 4). If allowed to continue, the berm will grow and prevent water from flowing off the trail, causing gullying down the centerline of the trail (Stage 3). If this centerline gullying is allowed to continue unchecked, the trail will trench deeper and deeper until it is both unusable and unredeemable (Stage 4).

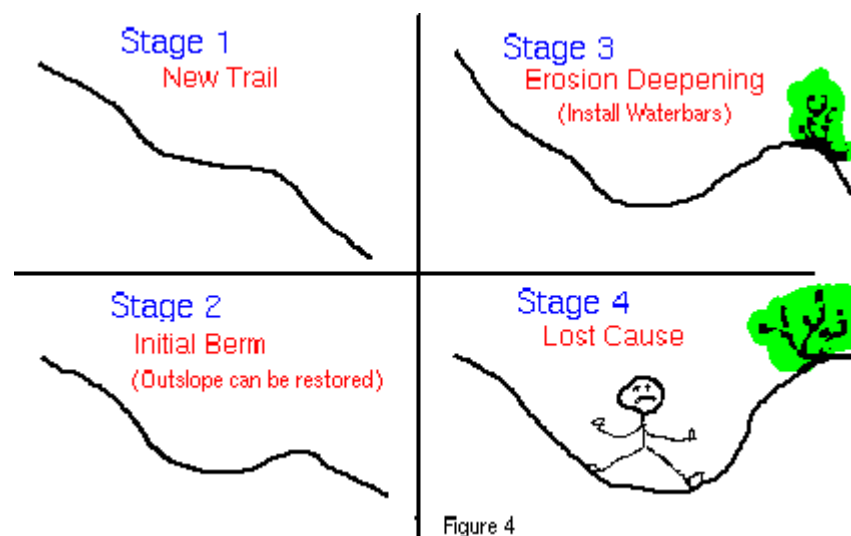

The outslope is maintained at Stage 2 by simply pulling the small 4" - 5" berm back into the trail tread. This unglamorous work must be performed again and again by trail crews, but in many cases, if the outslope is restored on a regular basis, little or no maintenance is needed of any other kind. However, some use patterns (extensive equestrian use), soil conditions (sandy) and climate conditions (high precipitation) combine to minimize the effectiveness of this maintenance tool; it just has to be done too often to make it worthwhile.



Once a trail has reached Stage 3, the berm is too large and overgrown with vegetation to be removed; the outslope cannot be restored and other maintenance approaches must be employed. When a trail deteriorates to Stage 4, the trail is a lost cause, and the best solution is trail abandonment and relocation.

### **Install and Maintain Water Bars**

Water bars divert water off a trail at controlled points along the trail. They can be incorporated in the original construction of a trail, or they can be installed later as a maintenance measure. Done well, a series of water bars can effectively eliminate erosion and stabilize a trail for years. Done poorly, water bars can accentuate trail erosion and become dangerous tripping hazards.

The most permanent water bars are made from native rock obtained on-site. When rock of a suitable size is not available, water bars can be made from 4 x 6 redwood timber, or native logs. Peeler logs or other landscaping products should not be used because their appearance is foreign to a natural environment. Bicyclists prefer a new product made of black rubber that diverts water, but is flexible enough to allow cyclists to easily cross. However, this too, may be inappropriate for a natural environment.

There are many options about the proper installation of water bars. Three trail handbooks will promote three different approaches. Well, here is one more. The elements of a properly installed water bar are:

1. **Set the water bar at a 60 degree angle** across the trail. A water bar set perpendicular (90 degrees) across the trail will not divert the water off. A water bar set 30 degrees across the trail can be awkward to hike or ride over.
2. **Extend the water bar such that water is carried completely off the trail** to a steep side slope. Otherwise, the water flow will bypass the water bar and erosion will occur.
3. **Provide rock at the downslope end** of the water bar to dissipate the energy of the flowing water, thereby minimizing erosion.
4. **The top of the water bar should be nearly flush with the trail tread** to minimize tripping hazards. On first consideration, it may not make sense to make the top of the bar flush with the tread because there would be nothing to "catch" and divert the water. However, we are not concerned about diverting **all** water flowing down a trail, only that amount of water than causes erosion. With the bar flush, its effectiveness only kicks in when there is enough water to erode away a lip on the uphill side of the water bar, which then allows the bar to divert the water flow.
5. **The boulders used for rock water bars must be huge**, otherwise, they will be kicked out of place by a horse. The rocks should overlap like shingles on a roof to prevent water from flowing between rocks and eroding away the integrity of the water bar. In addition, long boulders with one flat side work best to prevent tripping hazards.

Water bars need regular maintenance. The excess soil and debris that build up at the downslope end of the water bar needs to be periodically graded out to assure that water flows off the trail. **Without regular unplugging, a water bar is useless.**

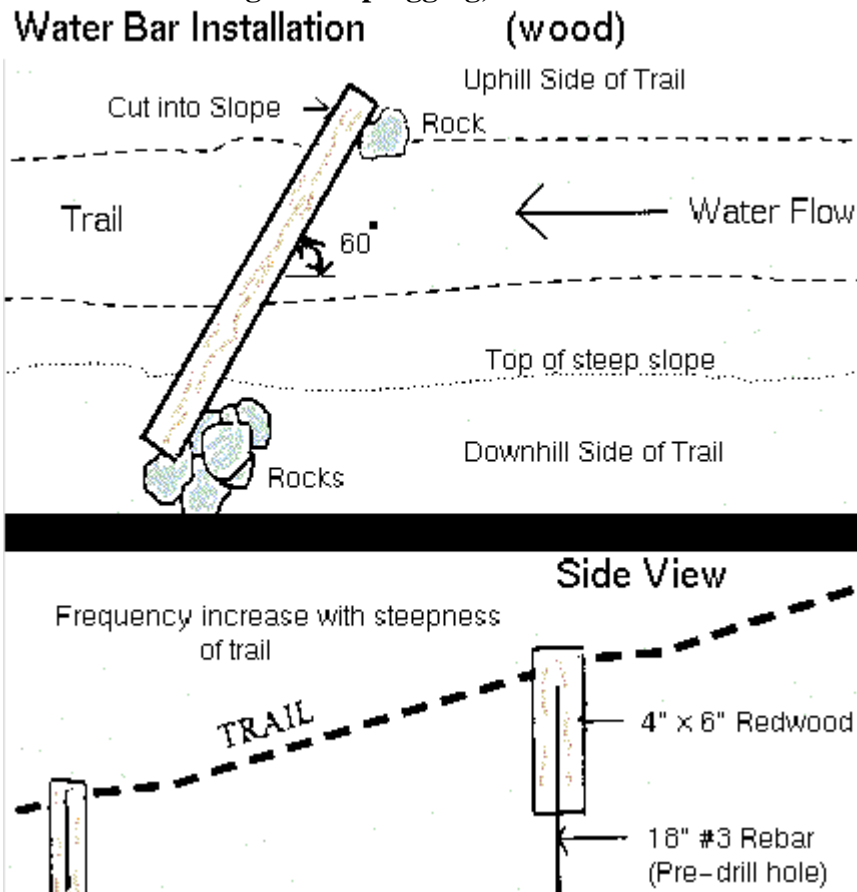

### Maintaining Drainage Dips

A drainage dip is built into the original trail alignment and is a change in gradient (a "dip" in the trail) that dissipates and diverts water flow (it's like a built-in water bar). Like a water bar, it only remains an effective means of erosion prevention as long as regular maintenance keeps it unplugged.

### Pruning

Pruning vegetation is an essential and regular part of trail maintenance, especially in brushy chaparral areas. Multi-use trails should have 10' vertical and 8' horizontal clearance (though there will be exceptions for the sake of protecting a tree or skirting around a large boulder).

Too often, trail pruning is accomplished in the most expeditious manner possible -- a branch intrudes within the walking/riding space of the trail and is quickly lopped-off so that it doesn't intrude and the debris is indiscriminantly tossed aside. However, our goal in trail maintenance is to **maintain a trail in as natural appearance as possible**. A quick pruning job deals only with the function of trail maintenance, not the aesthetics.

There are 6 elements of acceptable pruning in the State Park System. Each of these elements makes pruning a more tedious maintenance task, but results with a trail that is compatible with the natural environment.

1. **Do not toss debris!** Branches that are randomly discarded usually end up hanging in adjacent shrubs or trees. These dead branches are both unsightly and create a fire hazard.
2. **Place debris out of view.** This element requires the extra effort of dragging branches under and around shrubs.
3. **Place the butt (cut) end away from the trail.** This will help disguise the debris.
4. **Each cut branch should be touching the ground to promote decomposition.** This means that brush piles are not appropriate.
5. **Pruning should be done sensitively so that the trail appears natural** and not as if a chain saw just blasted through. Trail users should not be aware that **any** maintenance work has recently been done.
6. **Prune to the collar of any branch stem** for the health of the shrub and a more natural looking result. At the base of any branch there is a wide section that contains a plant's natural healing agents. Any pruning performed away from this collar will expose the plant to a greater risk of infection. A cut at the collar will naturally heal. For large branches over 2" in diameter, cut from the bottom, then cut down from the top. This prevents tearing of the bark, reducing infection.

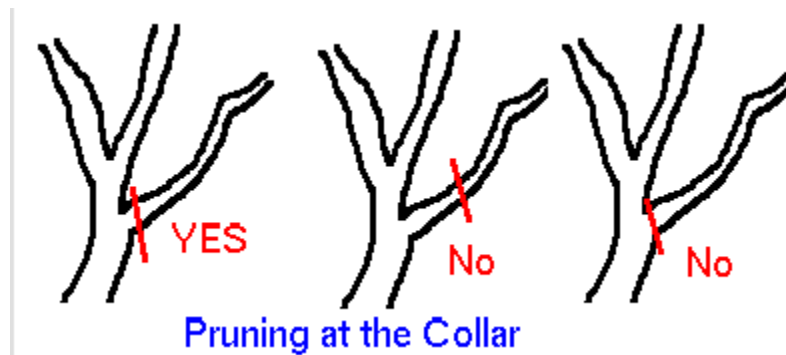

## Signing / Mapping

Adequate signing and mapping keeps trail users on the trail. Uncertainty about which trail is which will lead to new trails being created by trail users. These new trails will become maintenance headaches and will ultimately need to be abolished.

## Check Dams

Check dams are a popular, though generally ineffective, instrument of trail maintenance. A wood timber is placed 90 degrees across a trail. In theory, the check dam is intended to slow the velocity of water flowing down the trail, thereby reducing erosion. In reality, nearly all check dams only halt erosion in the 2 to 3 feet immediately behind the check dam, but accelerate erosion immediately below and beside the dam. This is because they never take the water off the trail, they only slow it down momentarily. For check dams to be truly useful in stopping erosion, they need to be spaced 3 feet apart, and this effectively makes a stairway out of the trail.

Check dams should not be used in trail maintenance. However, they may have limited application in restoring abandoned trail alignments to natural conditions.

### **Import Fill Material**

A deeply trenched trail can be restored by importing dirt or decomposed granite, compacting it, and recreating a well-drained outsloped trail. However, in most situations, this approach is usually both cost prohibitive and far too labor intensive.

### **TRAIL REROUTING**

Trail rerouting is beyond the responsibilities of a trail maintenance crew. New trail alignments must be flagged by experienced park staff and then reviewed by resource specialists for compliance with the California Environmental Quality Act. Trail maintenance crews can provide valuable assistance by alerting park staff to those trail routes that may need to be rerouted.

There are two measurements that dictate that a trail relocation is needed:

1. When the maintenance crew is dealing with a poorly designed trail that has deteriorated to the extent that remedial measures will not work or will constantly need repair or replacement, AND
2. A significantly better route is available.



The telltale signs of a trail that needs to be relocated are: deep trenching and a gradient exceeding 20% over about 100 feet of trail.

### **REFERENCE MATERIAL**

This document represents a cursory look at the basic aspects of trail maintenance and only briefly touches on trail construction techniques. There are many valuable references that dive into much greater detail; a few are listed below. Each of them can be obtained by contacting the sponsoring agency.

**NPS TRAILS MANAGEMENT HANDBOOK**, United States Department of the Interior, National Park Service, Denver Service Center, 1983 (A small, but comprehensive, pocket manual on trails construction and maintenance.)

Trails Coordinator, National Parks Service  
P.O. Box 25287, 655 Parfet Street, Denver, CO 80255

**A TRAIL MANUAL**, East Bay Regional Park District, Oakland CA. 1976

**GUIDE FOR MOUNTAIN TRAIL DEVELOPMENT**, United States Department of Agriculture, Forest Service, 1984

Forest Service - USDA  
 Engineering Staff - Washington Office, Attn: Publications Specialist  
 P.O. Box 2417, Washington, D.C. 20013  
 (703) 235-8198

**TRAIL DESIGN, CONSTRUCTION, AND MAINTENANCE**, Appalachian Trail Conference, Harper's Ferry, 1981

Appalachian Trail Conference  
 P.O. Box 236, Harpers Ferry, WV 25425  
 (304) 535-6331

**TRAILS MANUAL**, Charles Vogel, 1968

Equestrian Trails, Inc.  
 10723 Riverside Drive, North Hollywood, CA

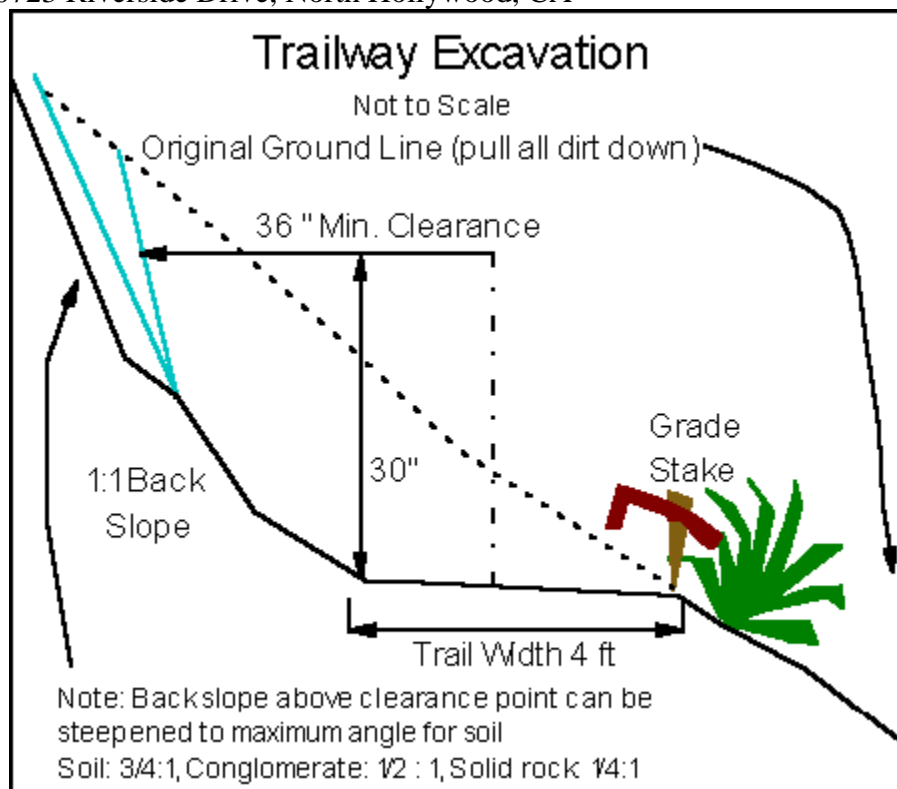

This document is available at <http://www.wta.org/~wta/cgi-bin/wtaweb.pl?6+tw+index>

## Drainage Structures

### WATER PROBLEMS

The biggest natural enemy of our trails system is water. Seasonal stream beds rage across trails ripping out large sections. Standing water from heavy down pours creates boot-sucking mud-holes. Snow melt runs down hillsides and erodes trails. Hillsides saturated with water give way sending tons of mud sliding across trails. Is there anything we can do about it? We certainly can't make it stop raining, not in the Northwest.

There are some practical solutions to keeping water off our trails. Typically the greatest cause of harm by water is when it sees the trail as the path of least resistance and so runs down it turning the trail into a stream-bed washing away the soil leaving exposed roots and rocks. There are two ways to prevent this from happening. The first, explained in the **Rebuilding Tread** section of this guide, is to build a trail with a proper outslope to guide water off the edge. The second is to divert water off the trail or slow its progress before it can do much damage. To do this we turn to some common drainage structures, **drain dips, waterbars, check dams** and **culverts**.

The Drainage Structure Order of Operations	
<b>Outslope the trail</b>	More time consuming, but the best solution.
<b>Drain Dip</b>	Drain dips are simple and effective, but must be properly built and routinely maintained if they are to last.
<b>Waterbars</b>	More elaborate structures that require considerable time and materials to build, but are often necessary in heavily used, steep, or very wet trails.
<b>Culverts</b>	Use in heavily trafficked trails in conjunction with side ditches and turnpikes.
<b>Check dams</b>	Used only in badly eroded, trenched trails. They don't remove water from the trail, but stop further erosion

### DRAIN-DIPS

A **drain-dip** or **grade-dip** is a wide, shallow depression sculpted into the tread. Grub hoes and McLeods are great for making drain-dips. The dip should completely cross the trail and be cut at an angle with the outside edge end of the drain-dip further down-trail than the other end. The dip should have an **outslope** (the outside edge should



be lower) to carry water off the trail. The up-trail side of the dip should have a gradual slope. A McLeod or shovel is good for doing this. A well constructed drain-dip is often not even noticed by hikers. It appears to be a shallow, naturally occurring dip in the trail. If the dip is expected to carry a lot of water it's a good ideal to build a small rock **spillway**. Piling rocks at the outlet of the drain-dip will slow the erosion of the outside edge of the trail.

Drain dips are great, but they don't last very long. They can quickly become filled in with silt. For a long term solution we need something hardier.

### **WOOD WATER BARS**

**Waterbars** are drain-dips that have transcended to a higher state of being. They are like drain-dips, but are re-enforced with either rock or a log to help sustain a greater volume of water. Rock waterbars last much longer than wood waterbars, but take longer to make and require a long search for suitable rocks.



To build a wood **waterbar** dig a deep trench across the trail at somewhere between a 45 and 60 degree angle. The angle is important to reduce the rate at which the waterbar collects silt. If the waterbar is placed straight across the trail it will collect silt quickly and stop working. Next place a peeled log between six to eight inches in diameter in the trench. The log should be embedded at least a foot deep into the hill on the inside edge of the trail. This will help hold it in place. The log should be long enough to span the entire width of the trail. The outside-edge end of the log should be held in place either by wooden stakes, the weight of a large rock, or even steel rebar passing through the log. The down-trail side of the log should be completely back-filled with mineral soil so that no more than one or two inches of the log appears above the surface. The uphill side of the log should have a wide, shallow dip with an outslope much like a drain-dip. At low volumes water will follow the drain-dip off the trail. At higher water volumes the log itself will catch and direct water off. Waterbars should also have a rock spillway to slow erosion.

### **ROCK WATER BARS**

**Rock Waterbars** last much longer than wood water bars but can be more time consuming to build. First you must construct a trench at a 45 to 60 degree angle across the trail as with a wood waterbars, then place rocks in the trench to re-enforce the down-trail, water-catching side. Finding and positioning the rocks is the challenge. The ideal waterbar rock is a solid rectangular shape about .5 meters long by .3 meters high and .1 meters thick. Rocks like these don't exist in the back country. Nothing even close to this exists in the back country, but it pays to invest some time in finding rocks that are as rectangular as possible.



The rocks should be placed in the drainage ditch so that they are 2/3 buried and they should be overlapping such that the outside-edge-most rocks are fit behind their



inside edge most neighbor. This will reduce the chance of the water sneaking through any cracks between the rocks. The rocks should be fit as closely together as possible and any gaps between them should be filled in with smaller rocks, gravel and mineral soil.

Complete the project by back-filling the down-trail side of the waterbar with mineral soil so that no rock is sticking above the surface. Grade the up-trail side to produce a gradual, out-sloped trail-bed leading into the waterbar.

### CULVERTS

When large volumes of water need to be moved across the trail at a single spot, culverts are used. Culverts are often used in conjunction with **turn pikes**. The culvert must be buried at least 8" deep and packed in a surrounding layer of rock and gravel to keep them from being damaged by trail traffic. Water is fed into the culvert by uphill ditches running parallel to the trail. When a turnpike isn't used, the ends of the culvert must be covered with arches of large rock to prevent them from being dented. Today, most culverts are made from attractive stealth-black plastic so they don't show up on radar. Older culverts may be made of aluminum or even wood. Culverts require extra work to maintain and should only be installed in heavily used or heavily impacted areas.



### ROCK CHECK-DAMS

When a trail becomes so badly eroded that it has turned into a deep trench, it can be difficult to divert the water off the trail. This is when we need to get water to work for us by building a **check-dam**. Check-dams (also known as **check-steps**) can be made by building a sturdy wall from large rocks across the trail. The rocks should be large and securely embedded into the ground with as much as 2/3 of the rock buried to insure it won't move. Fill behind the wall with rocks and **mineral soil**. Large flat rocks should be embedded in the trail beneath check steps to prevent erosion from trail users when they step down. The completed project will look like a step. Water will continue to run down the trail, but the check-dam will trap sediment behind it keeping it filled. When a long stretch of trail is badly eroded it is best to build a long series of check-dams like a staircase. Make sure none of the steps are higher than 9".



Rock check-dams are very natural in appearance and will continue to do their job for many years. If you're an avid hiker you've probably stepped over hundreds of them with out realizing it.

### WOOD CHECK-DAMS

Check-dams are often built out of wood. Begin by





selecting a log about 12" in diameter and 2' longer than the width of the rutted trail. Cut notches a foot back into the banks on either side of the trail. Place the peeled log into cuts. It should be spanning the trail at a 90° angle. Place stakes on the down-trail side of the logs or use rebar to hold the log in place. Fill in behind the log with rock and **mineral soil**. Large flat rocks should be embedded in the trail beneath check steps to prevent erosion from trail users when they step down.

When several wooden check-dams are built in a series the final effect is a handsome flight of steps that will withstand years of water running down the trail.

This document is available at <http://www.wta.org/~wta/cgi-bin/wtaweb.pl?6+tw+index>

## Building Turnpikes

If you've hiked much in the Northwest you've probably encountered a **mud-hole** or two. Sometimes mud-holes are caused by a small amount of organic matter on the trail in an area that's poorly drained. These are easy to fix with a little scraping and a drain-dip. More often than not, however, mud-holes are caused by large deposits of organic material, perhaps a large, buried tree that fell hundreds of years ago or may be the trail was built through a bog. The soft, rotting organic material traps water and foot-traffic stirs it up into a muddy mess. As people try to go around the mud-hole it gets bigger and wider. When well-intending people start throwing bark, sticks, logs or pine bows into the the mud-hole it just makes it worse. They're just adding more organic material.



Big mud-holes or boggy areas are ideal locations for a **turnpike**. A turnpike is an elevated walkway constructed of two parallel logs or rock walls filled in with rock and **mineral soil**.

To build a turnpike scrape out as much of the muck as possible. Next dig two shallow, but wide parallel trenches 2-3' apart from one another running along either side of the trail. Put peeled logs 10-12" in diameter into the trenches and place stakes along the outside edges to hold the logs in place. Logs may also be held in place by driving rebar through them into the ground or by connecting them with cross pieces as shown here. When using cross pieces, lap-joints should be used when nailing the pieces together. Rocks may also be used instead of logs. When building rock turnpikes, very large rocks must be used and they must be deeply embedded into the ground to ensure they don't slip out of place. Turnpikes should also have **end caps** - a piece of wood or line of embedded rocks on each end to retain all the fill you'll be putting in the turnpike in the next step.



**Note: Only a twit would build a turnpike without end caps**



Fill the turnpike with large, flat rocks as big as you can carry, but not so large that they stick up higher than the logs. Next fill the turnpike with smaller rocks and then even smaller rocks filling in the empty spaces between larger rocks as you go. Finally fill the turnpike with fine mineral soil putting enough to form a crown higher than the logs on either side. This will keep water from pooling in the turnpike.

Trenches on either side of the turnpike should be dug and connected to drain-dips or culverts to allow water to flow around the turnpike and off the trail. Often culverts are placed underneath turnpikes. The final product can be very attractive and durable.

This document is available at <http://www.wta.org/~wta/cgi-bin/wtaweb.pl?6+tw+index>

## Building Puncheon

When drainage structures just don't work, when the ground is just too wet and muddy for a turnpike, it's time to build some puncheon. Puncheon is an elevated wooden walkway built to cross swampy or boggy areas. In the back country they're often built from felled logs. Building a piece of puncheon this way is challenging and time consuming. If the puncheon to be built is close to a trailhead it's often easier to bring in dimensional lumber. The puncheon shown below is built from treated cedar -- the material of choice.



### Step 1: Setting the mud-sills:

The most crucial part of building a stretch of puncheon is setting the **sills**. The sills are the part of the puncheon that make contact with the ground and upon which the rest of the structure sets. The sills must be properly positioned to ensure the puncheon is level and headed the right way. This means excavating, positioning the sills, measuring with a level and guide string, then repeating the whole process over again until every thing is perfect. Any errors made here will be amplified in further steps. Placing mud-sills can be particularly challenging when you're standing in half a foot of mud under half a foot of water.

### Step 2: Placing and connecting the stringers:

**Stringers** are placed on top of the sills. They run lengthwise along the puncheon. Stringers are connected to the sills by drilling through the stringer into the sill and then nailing it down with a large nail. Sometimes a drill hole is made all the way through the sill and a piece of steel **rebar** is pounded deep into the ground as well.





### Step 3: Placing the decking:

The **decking** is the traveling surface of the puncheon. In the back country it's often made from thick slices of split cedar. Here we're using cedar 2x4s for our decking. The decking is carefully placed to make sure there's just enough space between each piece to allow loose change and car keys to fall between them. After a piece of decking is positioned it's nailed to the stringers.

### Step 4: Admiring your work:

This piece of puncheon built by the WTA on March 20-21 1997 can be found on the Champion Tree Farm Nature Trail near lake Kapowsin just south of Orton. The trail is being built with the help of WTA volunteers to allow Champion's wildlife biologist to give disadvantaged youth a chance to enjoy some of the great outdoors that those of us who are avid hikers often take for granted.

The trail leads into an environmentally sensitive wetland area set aside by Champion. The puncheon itself runs along the edge of a pond traveling over several inches of water and mud. It will allow young nature-lovers to get a closer look at ducks, cat-tails, water bugs and a chorus of Pacific Tree frogs.



### A review of basic puncheon terminology

showing the relationships between **sills**, **stringers** and **decking**.



This document is available at <http://www.wta.org/~wta/cgi-bin/wtaweb.pl?6+tw+index>

## Rebuilding Tread

To keep a trail in good shape we need to keep water off of it as much as possible. Our job is made much easier if we build the tread properly in the first place. A typical hiker trail should be two feet wide and have a gentle **out-slope**. This means the **outside edge** of the trail should be lower than the **inside edge** of the trail -- about two inches lower for a two-foot wide tread. This will encourage water to run off the trail rather than down it. The forces of nature don't care much for this design and are continually working to undermine it.



Three major factors work together to ruin a trail. First, mud and other debris slide down onto the trail. This is called **slough**. Slough blocks or narrows trails. Second, plants growing along the outside edge of the trail cause the formation of **berms**. Berms trap water on the trail leading to erosion. Lastly, trail users whether wheels, hooves or boots wear down the tread with heavy use.

When rebuilding trails we use McLeods, Pulaskis, grub hoes and shovels to remove slough, dig out berms and widen the path and restore the tread to its proper design. The completed tread should be two feet wide with the outside edge of the trail being about 2" lower than the inside to facilitate run-off. All **duff** should be removed from the trail leaving behind only **mineral soil**. Duff is the term for the organic matter that litters the forest floor: leaves, pine needles, twigs, bark, etc. Mineral soil is soil that is low in organic content. Soil high in organic content holds water and forms boot-sucking **mud-holes**.

When a trail is too eroded from over-use or heavy water damage, we need to consider building raised trail structures such as **turnpikes** or **puncheon bridges**.

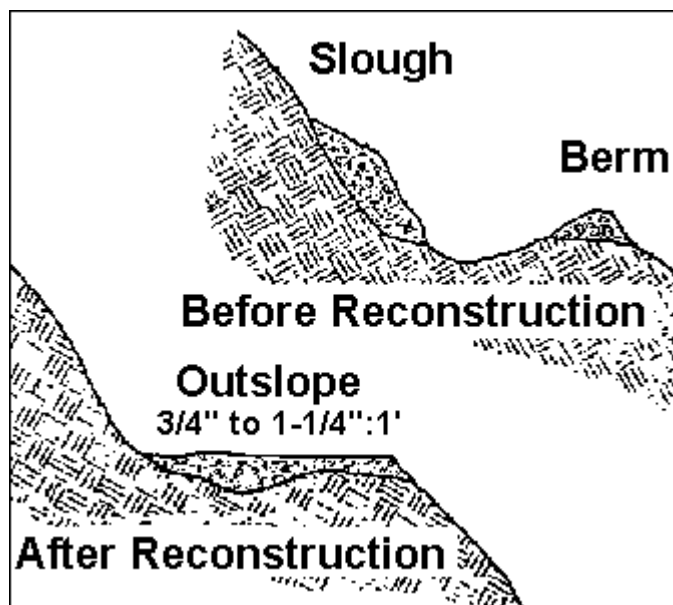



This document is available at  
<http://www.americantrails.org/resources/trailbuilding/Geotextile.pdf>

# THE TRAIL FORUM

Conducted by Kim Frederick, Jefferson County Open Space  
 Lois Bachensky, U.S. Forest Service, Rocky Mountain Region

## Geosynthetics for Trails in Wet Areas

By Steve Monlux, USFS R1 Engineering

*Trails on soft, water-saturated soils present special challenges. Improper construction of trails in wet areas leads to soil compaction, sedimentation, multiple trails, and unhappy trail users. Turnpike or puncheon has worked well where rock or wood materials are readily available, but the use of geosynthetics can increase the effectiveness of trail construction methods and offers additional alternatives. Geosynthetic materials have been used increasingly in trail construction over the past 10 years. We present here some guidelines and product information for trail managers.*

**Geotextile**, often called "construction fabric," is primarily used for separation and reinforcement over wet, unstable soils. It can both support loads and allow water but not soil to seep through. **Geonet** has a thin polypropylene drainage core covered on both sides with geotextile, which provides more reinforcement in addition to separation and drainage.

**Geogrid** is a more open polyethylene structure with high tensile strength that can interlock coarse aggregate into the grid structure.

### General Guidelines for Geosynthetic Use

Geosynthetics are usually placed directly on the natural ground without prior excavation and covered with trail tread material. Less tread fill can be used over geosynthetic products that are rigid or have high bending strengths because the weight of fill is distributed over a larger area. For example, much more tread fill is required for a single layer of geotextile than for geocell with geotextile. In this example, the cost of importing tread fill must be compared to the increased cost of the geocell.

Alternatives that use tread fill should have a crowned surface to shed water quickly, improve stability, and control erosion and sediment. After backfilling, there will be some settlement depending on soil type, level of saturation, and the weight and depth of fill. Additional fill may then be necessary to maintain the crown due to settlement or tread wear. In all cases keep geosynthetics covered to protect them from ultraviolet light and traffic abrasion.

### Geotextile or Geonet (single layer)

This basic application places fill on a single layer of geotextile or geonet which (a) separates fill material from saturated soils, and (b) distributes fill weight so less settlement takes place. Since geonets cost more, use them only where drainage and subsurface moisture conditions are worst. Avoid using organic, silty, or clayey soils for trail tread material since little subsurface drainage will occur, and the trail tread will become muddy in wet weather. Rocky soils or crushed aggregate are the best tread materials since they retain much of their strength when saturated. Excess surface moisture can drain off through these permeable materials if the trail is located on a grade or side slope.

### Geotextile with Encapsulated Free Draining Rock (Sausage Technique)

This application involves encapsulating native or free-draining rock in a piece of geotextile and placing fill on top. The geotextile provides separation from the saturated soil, and the rock provides drainage for excess water. One-inch flexible plastic pipe outlets for subsurface water may be desirable where trails are constructed on very flat terrain to avoid the 'bath tub' effect. If the trail has grade, and or if built on a side slope, other drainage options exist.

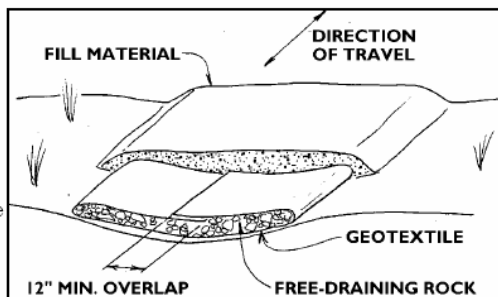

The rock may be single size material from pea gravel to cobbles (3-12") or a mixture of rock material that does not contain silt or clay. The free-draining rock can be placed to a thickness equal to the largest rock if only drainage is desired. If reinforcement is also needed, at least 3" of rock is recommended. The geotextile is wrapped over the rock layer with a 12" overlap to ensure encapsulation, since settlement of saturated soil can pull the overlap joint apart.

### Geotextile with Poles, Logs

This turnpike application involves wrapping poles, logs, or saplings in geotextile with the poles parallel to the trail. This structure requires less fill and resists being pushed down into soft soils. No subsurface drainage is provided with this design, but longitudinal drainage may occur along the poles if the trail slopes. Another approach is to cut logs to the trail width and place them crosswise, but it does not use log bending strengths as effectively and is more labor intensive. Use an outlet pipe to provide drainage where trails are on a grade or side slope.

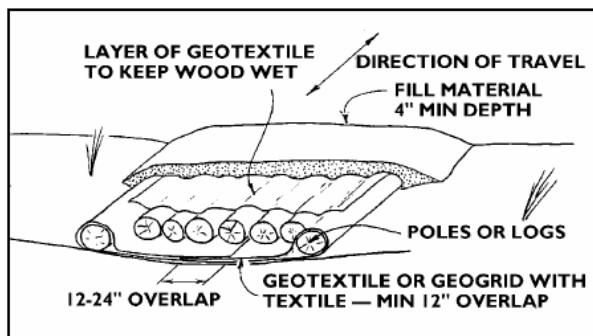

Soil settlement is minimal because the wood structure is light weight; the bending strength of wood distributes the weight of fill and traffic; and wrapping trees together with geotextile distributes loads. This method is attractive for areas with wood but not much rock for drainage, and for swampy areas where flotation and bending strength of wood is used. Wood must be kept constantly wet or dry to control rotting. A layer of geotextile down the centerline over the logs will help keep them saturated and securely positioned below the trail tread surface.

### Geogrid with Geotextile or Geonet

Geogrid placed on top of the geotextile or geonet adds bending strength to the system, and decreases settlement and amount of fill material required. Very little drainage is required with this design unless geonets are used, or if the tread material is permeable (rocky soils or crushed aggregate). The geogrid should be pulled taut to remove wrinkles prior to staking. The stakes and poles provide some pre-tension of the grid, to better utilize its strength. The geotextile or geonet provides separation from the saturated soil and keeps the drainage paths along the bottom of the fill material from clogging.

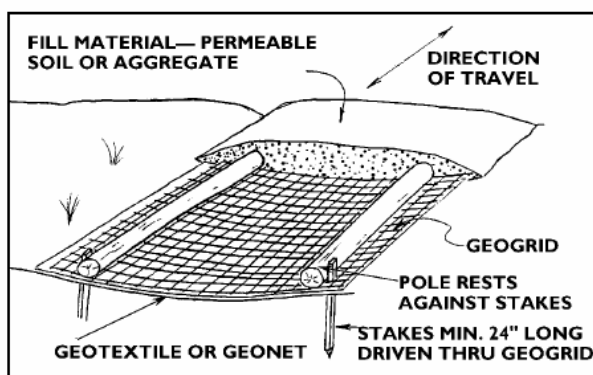

### Sheet Drains under Tread Fill

The sheet drain provides separation from saturated soils and distributes the trail tread weight to limit settlement. Install the product with the plastic core side facing up, and the fabric side facing down. This orientation takes advantage of the plastic core compressive strength and the fabric's tensile strength to reduce settlement and fill required. One-inch diameter flexible plastic pipe can be used as a drainage outlet to take full advantage of the drainage capability of the sheet drain.

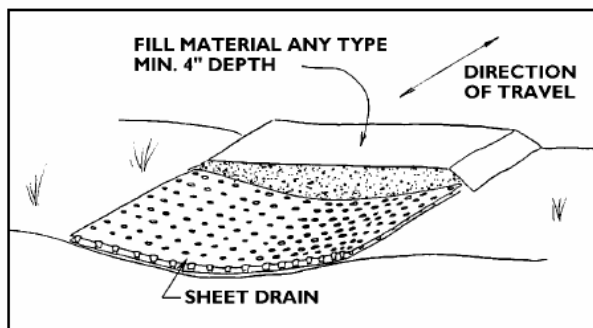

### Sheet Drains Used as Drainage Cutoff Walls

If the trail section is on a side slope where subsurface water saturates the uphill side of the trail, a cutoff wall will intercept surface and subsurface moisture and help drain and stabilize the trail section. This application is especially beneficial where cut-slope sloughing fills in ditches. The sheet drain is placed vertically along the uphill side of the trail within 3 feet of the trail's edge.

Probe the saturated soil with a short length of #4 reinforcing steel to determine the proper depth of the collection pipe and location of the sheet. Collector and outlet pipes can be made from flexible plastic pipe. Keep the top edge of the drain above ground to capture surface runoff moving downslope. Cover the exposed sheet drain with large rocks to protect it from deterioration from sunlight. The collector pipe can be drained into an outlet pipe or with a sheet drain panel under the trail section. This application requires ditching for proper interception and drainage of water. More ditching is normally required on flatter terrain.

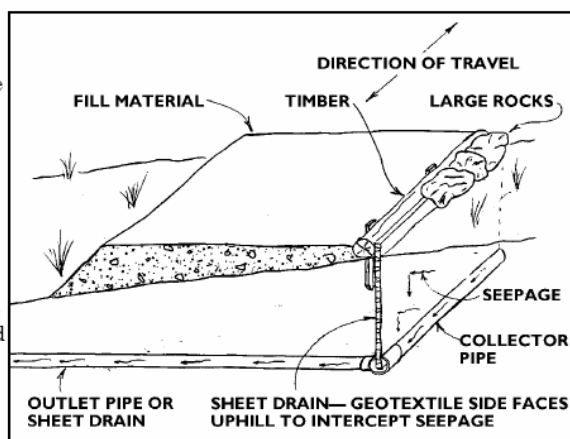

### Geocell Backfilled with Geotextile and Permeable Tread Material

The geocell provides confinement chambers which distribute the trail tread loads over a wider area and reduce settlement. The net effect is it increases the load bearing capacity of the tread and prevents feet and hooves from punching down into the trail. The geotextile provides separation between saturated soil and the tread fill. There is no subsurface drainage if the trail is on flat ground, but on a side slope, drainage will occur through the permeable tread fill. Sandy or rocky soils, crushed aggregate, or rock are desirable fill for geocells. Geocell itself does not increase the load bearing strength of clay or silt.

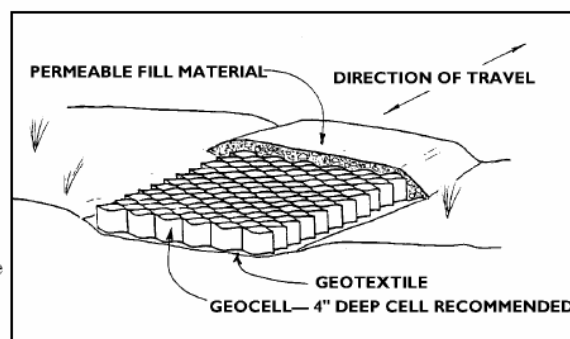

## GEOSYNTHETIC PRODUCT INFORMATION

The listed manufacturers and products were obtained from the *Geotechnical Fabrics Report, 1995 Specifier's Guide*. The products listed are ones that are readily available. Many other products from these and other manufacturers may be appropriate. Most manufacturers and Geotechnical/Materials Engineers can assist in selecting products if you provide details on soil and moisture conditions, expected loads (light loads for trails), etc.

Prices vary throughout the country due to shipping costs, but for comparison purposes prices are shown in dollars per square yard. Price ranges in parenthesis are in dollars per square yard although manufacturers may use other units or full roll quantities. All geosynthetic products can be either field cut or pre-cut by the manufacturer to meet width requirements and weight handling capability.

#### GEOTEXTILES Manufacturers

<u>Company Name</u>	<u>Phone Number</u>	<u>Product Name/Number</u>
AMOCO	(800) 445-7732	4545
Nicolon/Mirafi Group	(800) 234-0484	140N
Linq Industries	(803) 873-5800	130 EX

**Price range:** \$.63 to \$.72 per square meter (\$.53 to \$.60 per square yard)

**Typical product unit weight:** 0.13 Kg/square meter (0.25 lb/square yard)

**Notes:** These products are non-woven felt-like fabrics that are easier to work with than heat-bonded or slit film products that have a slick surface texture. Compare desired widths with standard roll widths for field or factory cutting. Costs are based on one roll quantities which normally cover 400 to 500 square meters (475 to 600 SY).

<b>GEONET Manufacturers</b>	<u>Company Name</u>	<u>Phone Number</u>	<u>Product Name/Number</u>
	Tenax	(800) 874-7437	Tenax TNT 204042
	Tensar Corporation	(800) 292-4459	DC 4205

**Price range:** \$3.50 to \$4.60 per square meter (\$2.97 to \$3.87 per square yard)

**Typical product unit weight:** 0.89 kg/square meter (1.64 lb/square yard)

<b>SHEET DRAINS Manufacturers</b>	<u>Company Name</u>	<u>Phone Number</u>	<u>Product Name/Number</u>
	Mirafi	(800) 234-0484	Miradrain 6000
	Contech	(513) 425-2165	C-Drain 15K
	Presto	(800) 558-3525	Amerdrain 500

**Price range:** \$6.50 to \$8.50 per square meter (\$5.40 to \$7.11 per square yard)

**Typical product unit weight:** 2.8 Kg/square meter (4.25 lb/square yard)

**Notes:** Compare desired widths with standard sheet widths and consult with manufacturers for field or factory cutting. Various core thicknesses are available. For example, Presto makes a product called Akwadrain with a 25mm core thickness with fabric on both sides, that has significantly greater bending strength which limits the settlement in soft soils, and reduces the amount of fill material required.

<b>GEOGRID Manufacturers</b>	<u>Company Name</u>	<u>Phone Number</u>	<u>Product Name/Number</u>
	Contech	(513) 425-2165	Tensar BX1100
	Tensar	(800) 292-4459	Tensar BX1100
	Carthage Mills	(513) 761-4141	FX-3000
	Tenax	(800) 874-7437	MS 300
	Huesker	(800) 942-9418	Fortrac 35/20-20
	Mirafi	(800) 234-0484	Miragrid 5T

**Price range:** \$2.15 to \$4.75 per square meter (\$1.80 to \$4.00 per square yard). Low-cost products are made from polypropylene, higher-cost products from coated polyester. Both product types are adequate for trails

**Typical product unit weight:** 1.75 Kg/square meter (0.34 lb/square yard)

**Notes:** Specify desired product widths and lengths for the project application.

<b>GEOCELL Manufacturers</b>	<u>Company Name</u>	<u>Phone Number</u>	<u>Product Name/Number</u>
	Presto	800-558-3525	Geoweb
	AGH	713-552-1749	EnviroGrid
	WEBTEC	800-438-0027	TerraCell

**Price range:** \$7.50 to \$11.30 per square meter (\$6.30 to \$9.45 per square yard)

**Typical product unit weight:** 1.55 Kg/square meter (2.9 lb/square yard)

**Typical product dimensions:** 4" x 8" (Depth x Length) and 20ft x 8ft (Length x Width)

**Notes:** Specify desired product widths for the project application. The 100 mm (4 inch) cell depth should be adequate for trails - depths from 50 mm to 200 mm (2 to 8 inches) are available. Consult manufacturers for availability of different section widths and alteration of standard section widths to fit your project needs.

*This information is taken from a draft report by Steve Monlux of the U. S. Forest Service's Missoula Technology Development Center in Montana. The full report on geosynthetics and their applications for trail construction will be available by October, 1995. For more information on this topic, contact Lois Bachensky, U.S. Forest Service Engineering, Rocky Mountain Region, 740 Simms, Lakewood CO 80225 (303) 275-5199.*

---

The next issue of The Trail Forum will appear in the July issue of Colorado State Trails News. Our planned topic is accessible trails for natural-surface, less-developed areas. Beneficial Designs of Santa Cruz, California, has been doing research on mapping, trail difficulty levels, and improving trail access, and we will report on some of their work and available publications.

---

This document is available at  
<http://www.dep.state.ct.us/burnatr/wildlife/factshts/abittern.htm>

---

## WILDLIFE IN CONNECTICUT

### ENDANGERED AND THREATENED SPECIES SERIES

---

### AMERICAN BITTERN

*Botaurus  
lentiginosus*

E  
N  
D  
A  
N  
G  
E  
R  
E  
D



E  
N  
D  
A  
N  
G  
E  
R  
E  
D

Copyright © 1997

**Habitat:** Freshwater and saltwater wetlands.

**Weight:** 1-2 pounds.

**Length:** 28 inches.

**Wingspan:** 42 inches.

**Life Expectancy:** Approximately 8 years of age.

**Food:** Frogs, salamanders, crayfish, water scorpions, diving beetles, dragonflies, killifish, pickerel, suckers, small eels, garter and water snakes, and occasionally voles.

**Status:** State endangered.

**Identification:** Adult American bitterns are large, somewhat stocky birds with yellow eyes, rich brown upperparts, and a white throat that is offset by black streaks. Dark flight feathers are conspicuous on the wing tips when the birds are in flight. The sexes are similar in appearance. Juvenile bitterns lack neck streaking.

**Range:** American bitterns occur from Central British Columbia east to Newfoundland, south, locally, to the Gulf Coast and west to southern California. They migrate south, but

not to the extent that many other wetland birds do. The species winters in the southeastern and Gulf States and as far south as Central America and Cuba.

**Reproduction:** American bitterns migrate north to breed from mid-April to early May. Unlike other members of the heron family, these birds are not colonial nesters. Male bitterns may be polygamous (more than 1 mate) and often have several females nesting separately within their territory. Females choose the nest site in wetland areas, usually on the ground or raised slightly on a platform of thick vegetation. The female also builds the nest, usually out of reeds, sedges and similar plant material. The nest is 6 to 13 inches high and 12 to 16 inches wide. The 2 to 5 elliptical, olive-buff to buff-brown, slightly glossy eggs are laid at daily intervals.

Incubation begins when the first egg is laid and lasts for 24 to 29 days. The female is responsible for both incubation and tending the young. Young bitterns differ in size. They leave the nest after about two weeks but continue to be tended nearby. Their age of independence and first flight is unknown.

**Reason for Decline:** The primary reason for the decline in American bittern populations is loss of habitat. The marshes and swamps upon which this species depends have been drained and filled for a variety of human uses including roadways, housing and commercial developments.

**History in Connecticut:** The American bittern was common in Connecticut during the late 1800s and it was a regular, but not abundant, resident of freshwater wetlands in the early 1900s. It is currently considered a rare migrant and uncommon nester, with only one confirmed Connecticut breeding location reported in the last decade.

**Interesting Facts:** The American bittern, like many other herons, is solitary and moves slowly and secretively through dense marsh vegetation. Bitterns are most active at dusk and through the night. If alarmed, a bittern will stand motionless with its bill pointed straight up and its body contracted. This habit gave the bird its regional names of sky-gazer, look-up and stake-bird. Bitterns that flush when startled give a nasal "haink" call and beat their wings rapidly as they take flight.

Bitterns call most often in the spring. A loud, guttural "pump-er-wink" is usually heard at dusk and gets its booming quality from a specialized esophagus. This unique call has led to many other common names, including water-belcher, mire drum and thunder pumper.

During the breeding season, the males perform a remarkable courtship walk displaying white fan-like ruffs raised over their back and shoulders.

**Protective Legislation:** *Federal* - Migratory Bird Treaty Act of 1918. *State* - Connecticut General Statutes Sec. 26-311.

**What You Can Do:** Support for strong wetland conservation legislation, along with water pollution control efforts, will help protect the habitat of American bitterns.



## Connecticut Range

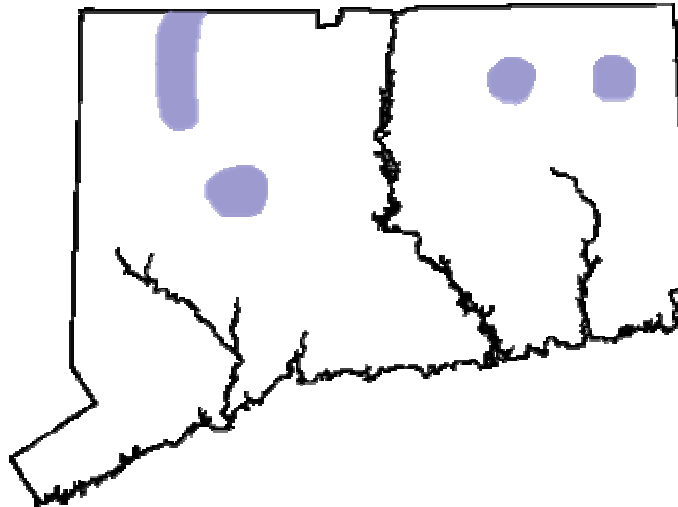

*The production of this Endangered and Threatened Species Fact Sheet Series is made possible by donations to the Endangered Species-Wildlife Income Tax Checkoff Fund.  
(rev. 12/99)*

[Top](#)

[Endangered and Threatened  
Species Fact Sheet Index](#)

---

## Bureau of Natural Resources - Wildlife Division

---

[Wildlife Division](#)

[Learn About  
CT's Wildlife](#)

[Common Wildlife  
Problems](#)

[Hunting &  
Trapping Info](#)

[Publications](#)

[Special  
Features](#)

*Last Edited January 2000*

This document is available at  
<http://www.dep.state.ct.us/burnatr/wildlife/factshts/ptbeet.htm>

---

## WILDLIFE IN CONNECTICUT

### ENDANGERED AND THREATENED SPECIES SERIES

---

### PURITAN TIGER BEETLE

*Cicindela puritana*

E  
N  
D  
A  
N  
G  
E  
R  
E  
D



Copyright © 1997 D

E  
N  
D  
A  
N  
G  
E  
R  
E  
D

**Habitat:** In New England, sandy beach habitat along the Connecticut River. Burrows are dug in upper shoreline areas with scattered vegetation and sandy clay soils.

**Length:** 0.44-0.56 inches.

**Life Cycle:** 2 years.

**Food:** Small insects, especially flies and ants.

**Status:** Federally threatened and state endangered.

**Identification:** The Puritan tiger beetle is a medium-sized terrestrial beetle. It has long legs and dark bronze-brown to green wing covers with cream-colored markings on the upper surface. This beetle often occurs with the more common *Cicindela repanda*, which is stouter, has white markings on the wing covers that do not connect along the edges, and is metallic blue-green under the body. In contrast, the Puritan tiger beetle appears longer and thinner, has whitish markings that connect along the outer margins of the wing covers, and has white hairs on the underbody. The Puritan tiger beetle appears whitish and shining in bright sunlight, while *C. repanda* is more of a chocolate brown and shows a blue flash from underneath when it flies.

**Range:** The Puritan tiger beetle is found only in two small areas which are separated by over 600 miles, one along the Connecticut River, in New England, and the other along the Chesapeake Bay, in Maryland. In the Connecticut River Valley, the species

distribution follows the sand and clay deposits formed by glacial lakes during the last ice age.

**Reproduction:** The Puritan tiger beetle emerges from the pupal stage as an adult in late June. Mating begins in mid-July and may continue until mid-August, when the adults start to die off. Females have been observed mating with more than one male and placing their eggs singly, just below the surface of the sand among scattered plants. After about a week, the eggs hatch into larvae about one-third of an inch long. The larvae dig a burrow an inch or two deep in the sand. They sit on top of the burrow, blocking the entrance with their large heads, and wait for prey, which they capture with their sickle-like mandibles (the principal jaws). After 2 to 4 weeks, the larvae molt into a slightly larger second stage, which dig deeper into the burrow, about 1.5 to 2 feet. By late October, these second-stage larvae close their burrows for the first of their two winter hibernations. In April or early May of the next spring, they open their holes and are active for a month or two, then close their burrows again until early September, when they molt to the third and final larval stage. These larvae remain active until late fall when they close their burrows for their second winter. The following spring, they are active until about June, when they pupate and transform into adults. The adult beetles then emerge from their burrows and begin the cycle again.

**Reason for Decline:** Puritan tiger beetle populations are limited by the availability of sandy beach habitat along rivers, which tends to occur below large river bends. Some historical sites where beetles occurred have been lost to bank stabilization around cities and by habitat loss due to flooding behind dams. The operation of flood control and hydroelectric dams has changed the way rivers flow and flood, possibly affecting the forces which create and maintain river beaches. At least one site, in Massachusetts, appears to be threatened by heavy recreational use.

**History in Connecticut:** The Puritan tiger beetle was collected in several towns from Middletown to the Massachusetts border in the late 1800s and early 1900s. Presently, they are found at a single cluster of 3 small sites. The total population in New England is less than 1,000; more than 99 percent of the remaining New England population is found only in Connecticut.

**Interesting Facts:** Like many insects, the Puritan tiger beetle has a complex life history. The immature stages look and act very differently from the adult. The adults are typical tiger beetles, active primarily on sunny days. They are long-legged predators which hunt by running along the sand, capturing small insects in their sharp, toothed jaws. In turn, they are preyed upon by dragonflies and robber flies. Puritan tiger beetles go through bursts of foraging activity, alternating with periods of standing still. The beetles' markings and color are cryptic, making them very difficult to spot if they are not moving. The larvae, in contrast, are somewhat like thin white caterpillars and are sit-and-wait predators. They almost never emerge from their vertical burrows. As the larvae move up and down their burrows, they smooth out the top of the hole, making it very round so that it almost appears to have been made by a drill. After rain or high water, they use their wide, flat heads like shovels to clear out sand that has fallen into their holes. Larvae have

hooks on the backs of one of their body segments, so that their predators find it difficult to pull them out of their burrows.

The Puritan tiger beetle leads a life of remarkable contrasts. It depends on areas which are disturbed enough to remain relatively open and free of plant cover, but not so disturbed that they wash away. Their habitat can be covered by floods in almost any month of the year, and larvae often spend a month or more under the water during spring floods. During the summer months, adults are active, but larvae close their holes and are inactive. This is probably to avoid parasitism by flies and wasps, which try to lay eggs on the larvae or drop their eggs down the larval hole. The parasitoid eggs, if successful, will hatch into larvae that attach to the back of the tiger beetle larva and eat it alive, eventually emerging from the burrow as an adult wasp or fly.

Although some other tiger beetles take only one year to develop, the Puritan tiger beetle takes two years, running the risk of being washed away by two successive years of spring floods. The beaches and banks of the Connecticut River are an unusual and rare habitat, and the Puritan tiger beetle has adapted to these unique challenges.

**Protective Legislation:** *Federal* - Endangered Species Act of 1973. *State* - Connecticut General Statutes Sec. 26-311.

**What You Can Do:** Plants and animals which live on beaches are under great pressure from development and recreation. Remember that the beach you are on may be some creature's living room--tread softly and treat it with respect.

## Connecticut Range

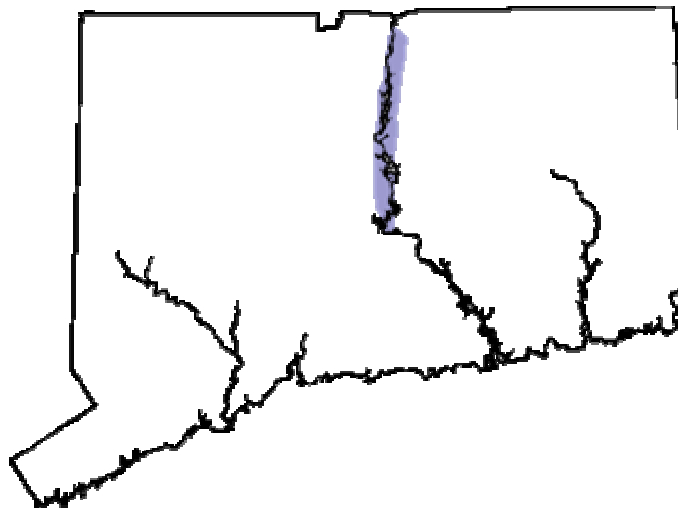

*The production of this Endangered and Threatened Species Fact Sheet Series is made possible by donations to the Endangered Species-Wildlife Income Tax Checkoff Fund.*

(rev. 12/99)

[Top](#)

[Endangered and Threatened  
Species Fact Sheet Index](#)

---

## Bureau of Natural Resources - Wildlife Division

---

[Wildlife Division](#)

[Learn About  
CT's Wildlife](#)

[Common Wildlife  
Problems](#)

[Hunting &  
Trapping Info](#)

[Publications](#)

[Special  
Features](#)

*Last Edited January 2000*

This document is available at  
<http://www.dep.state.ct.us/burnatr/wildlife/factshts/bldeagle.htm>

---

## WILDLIFE IN CONNECTICUT

### ENDANGERED AND THREATENED SPECIES SERIES

---

### BALD EAGLE

*Haliaeetus  
leucocephalus*

E  
N  
D  
A  
N  
G  
E  
R  
E  
D



E  
N  
D  
A  
N  
G  
E  
R  
E  
D

Copyright © 1997

**Habitat:** Natural year-round habitat almost exclusively lakes, rivers or seacoasts.  
**Weight:** Males, 8-9 pounds; females, 10-14 pounds.  
**Length:** 34-43 inches.  
**Wingspan:** 6-7.5 feet.

**Life Expectancy:** 25-30 years of age.  
**Food:** Fish; also anything that can be caught easily or scavenged such as waterfowl, small and large mammals, and livestock carrion.  
**Status:** State endangered and federally threatened.

---

**Identification:** Adult bald eagles have a snow-white head and tail, and a brownish-black body. The bill, eyes and feet are yellow. Immature eagles are uniformly grayish-brown. The distinctive adult plumage is attained at 4 to 5 years of age. The sexes are similar, although the females are larger. Young bald eagles are often confused with golden eagles; however, they are grayer than the darker golden eagle, and the bill is much heavier.



**Range:** The bald eagle nests from Alaska and Newfoundland south to Baja California, the Gulf Coast and Florida. It has recently returned to New England to nest. The greatest concentrations of wintering bald eagles are found from November to March in the western and Midwestern United States. Small concentrations of wintering eagles are also found in New England during this same time period.

**Reproduction:** Bald eagles breed in northern New England and Canada between March and April. They use the same breeding area, and often the same nest, each year. They reach sexual maturity at 4 to 6 years of age. The nest, which sometimes measures 7 to 8 feet across, is a flat-topped mass of sticks, with a lining of fine vegetation such as rushes, mosses, or grasses. It is built in trees, 10 to 150 feet above ground. There are usually 1 to 3 (average 2) dull, white eggs in a clutch. Both the male and female incubate the eggs and feed the young. The time period between egg laying and fledging is approximately 4 months. The entire breeding cycle, from nest construction to fledging of young, lasts 6 months.

**Reason for Decline:** Bald eagle populations declined because of human disturbance at nest sites; the loss of waterside habitat due to human occupation; the loss of nesting trees; intentional shooting by poachers; illegal trapping, mostly in the western United States; and contamination of food sources, especially by pesticides, with subsequent ill effects on health and reproduction.

**History in Connecticut:** Up to 100 eagles winter in Connecticut from December to early March along major rivers and at large reservoirs. This number is slowly increasing, but there is still a challenge to reconcile human population growth and urban/suburban sprawl with the specific needs of this endangered species. Bald eagles are infrequently observed during the summer. For the first time since the 1950s, a pair of bald eagles nested in Barkhamsted, Connecticut, in the summer of 1992 and produced 2 healthy chicks. The nest site in Barkhamsted continues to be used by a pair of bald eagles; chicks have also been produced at a new nest site along the upper Connecticut River, starting in 1997.

**Interesting Facts:** The bald eagle was first declared an endangered species with the passage of the federal Endangered Species Act in 1973. However, due to the banning of DDT, success of reintroduction programs through fostering of nestlings and hacking of fledglings, habitat and nest protection measures and other efforts to restore bald eagle populations, the U.S. Fish and Wildlife Service (USFWS) reclassified the bald eagle from endangered to threatened in the lower 48 states in 1996. While this reclassification does not alter conservation measures already in force to protect the bald eagle and its habitats, it is a step closer to the main goal of the Endangered Species Act, which is to restore endangered and threatened plants and animals to the point where they are viable, self-sustaining members of their ecosystems. Despite the reclassification of the bald eagle's status by the USFWS, the species remains endangered in Connecticut.

The bald eagle's range is restricted to North America. It was officially adopted as the national emblem of the United States of America on June 20, 1782.

Eagles are unable to carry much more than 4 pounds in flight. They kill prey by grasping it with their strong feet and sharp talons. An eagle's beak is used solely for tearing flesh. The flight speed of a bald eagle ranges between 36 and 44 miles per hour.

Despite their large size, eagles are disturbed by unpredictable human activity, making delineated protection zones necessary around areas of high eagle use. Since winter is a stressful time for eagles, it is important that preferred winter feeding areas be protected. If these birds are frequently disturbed from feeding and forced to travel to a different area for food, their lives may be threatened. Adult birds are disturbed more easily than juveniles.

At night, wintering eagles often congregate at communal roost trees; in some cases, they travel 12 or more miles from a feeding area to a roost site. Roosts are often used for several years. Many roosts are protected from the wind by vegetation or terrain, providing a favorable thermal environment. Use of these protected sites helps minimize energy stress. In addition, communal roosting may aid the birds in their search for food.

**Protective Legislation:** *Federal* - Endangered Species Act of 1973, Bald Eagle Protection Act of 1940, Migratory Bird Treaty Act of 1918. *State* - Connecticut General Statutes Sec. 26-93 and Sec. 26-311.

**What You Can Do:** Winter is a difficult time for any wildlife species, including bald eagles. Food is harder to find and cold temperatures cause energy stress. If you see a congregation of eagles feeding or roosting, leave them alone and observe them from a distance. It is also important to stay away from nesting areas to avoid disturbing the birds. The Wildlife Division participates in a mid-winter eagle survey for the United States Geological Survey; volunteers are always welcome to help in this effort.

## Connecticut Range

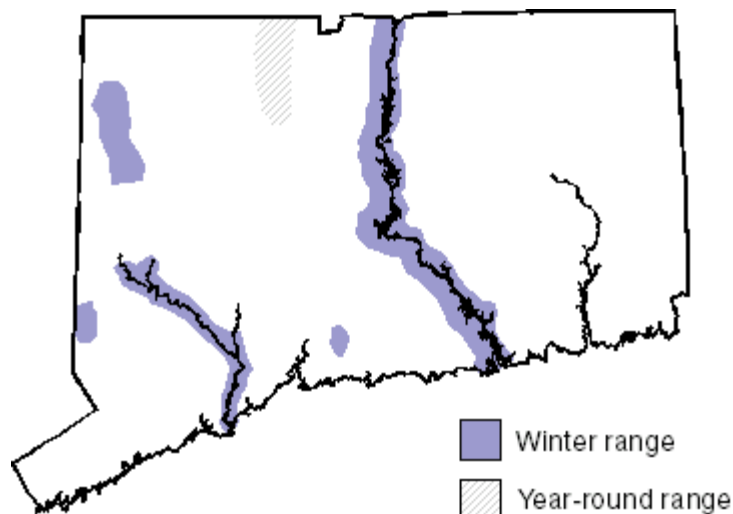



*The production of this Endangered and Threatened Species Fact Sheet Series is made possible by donations to the Endangered Species-Wildlife Income Tax Checkoff Fund.  
(rev. 1/00)*

[Top](#)

[Endangered and Threatened  
Species Fact Sheet Index](#)

---

## Bureau of Natural Resources - Wildlife Division

---

[Wildlife Division](#)

[Learn About  
CT's Wildlife](#)

[Common Wildlife  
Problems](#)

[Hunting &  
Trapping Info](#)

[Publications](#)

[Special  
Features](#)

*Last Edited January 2000*

## **ABOUT THE TEAM**

The King's Mark Environmental Review Team (ERT) is a group of professionals in environmental fields drawn together from a variety of federal, state and regional agencies. Specialists on the Team include geologists, biologists, foresters, soil specialists, engineers and planners. The ERT operates with state funding under the supervision of the King's Mark Resource Conservation and Development (RC&D) Area – an 83 town region.

*The services of the Team are available as a public service at no cost to Connecticut towns.*

### **PURPOSE OF THE TEAM**

The Environmental Review Team is available to help towns and developers in the review of sites proposed for major land use activities. To date, the ERT has been involved in reviewing a wide range of projects including subdivisions, landfills, commercial and industrial developments, sand and gravel excavations, active adult, recreation/open space projects, watershed studies and resource inventories.

Reviews are conducted in the interest of providing information and analysis that will assist towns and developers in environmentally sound decision-making. This is done through identifying the natural resource base of the project site and highlighting opportunities and limitations for the proposed land use.

### **REQUESTING A REVIEW**

Environmental reviews may be requested by the chief elected official of a municipality and/or the chairman of town commissions such as planning and zoning, conservation, inland wetlands, parks and recreation or economic development. Requests should be directed to the chairman of your local Conservation District and the ERT Coordinator. A request form should be completely filled out and should include the required materials. When this request is reviewed by the local Conservation District and approved by the ERT Subcommittee, the Team will undertake the review on a priority basis.

For additional information and request forms regarding the Environmental Review Team please contact the ERT Coordinator: 860-345-3977, Eastern Connecticut RC&D Area, P.O. Box 70, Haddam, Connecticut 06438, e-mail: ctert@comcast.net